

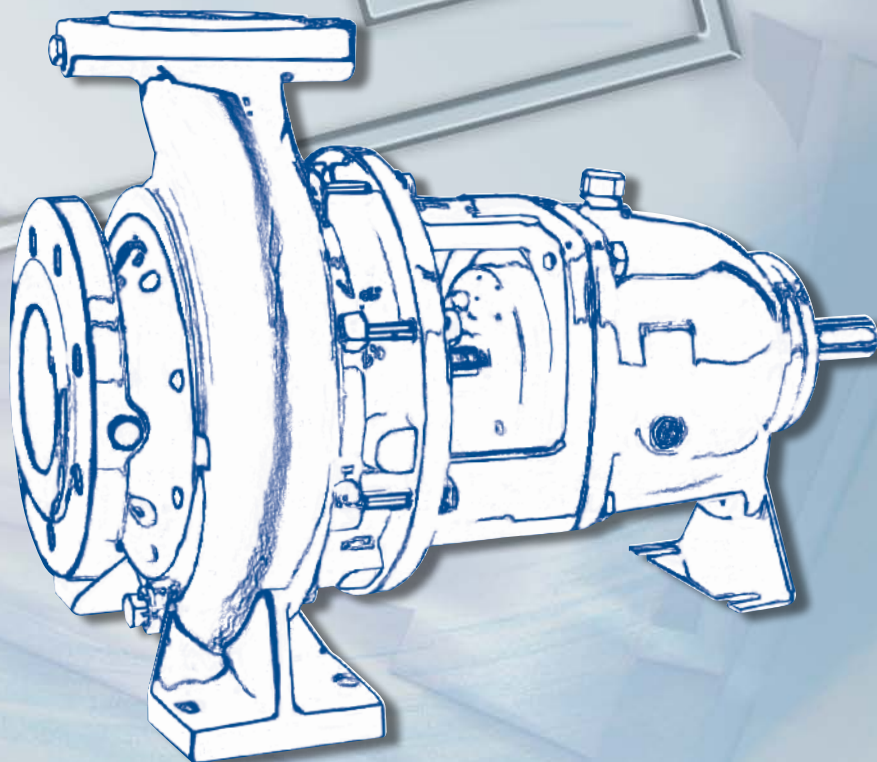

GARBARINO®

CN

Chemical pumps according to ISO 2858 - 5199
Pompe chimiche normalizzate ISO 2858 -5199





CN

CHEMICAL PUMPS ACCORDING TO ISO 2858 AND ISO 5199

POMPE CHIMICHE NORMALIZZATE
ISO 2858 E ISO 5199

GENERAL DESCRIPTION

CN Series are single stage centrifugal pumps, hydraulically balanced overhung impeller, simple volute casing, axial suction and radial discharge. Bearings are oil bath lubricated. The high standardization of the common parts simplifies spare parts storage. The bolting to the base plate through the casing feet together with spacer coupling, allow an easy disassembly of the rotating parts without disturbing the alignment and without disconnecting pipes and motor. UNI 2223-2229 NP 16 pipe flanges are used for standard construction. On request flanges can be drilled according to UNI NP 25, ANSI 150 RF or other standard.

GENERALITÀ

Le pompe CN sono pompe centrifughe monostadio ad asse orizzontale, girante a sbalzo idraulicamente equilibrata, corpo a voluta semplice con aspirazione assiale e mandata radiale verso l'alto. I cuscinetti sono lubrificati a bagno d'olio. Particolari comuni standardizzati permettono una migliore razionalizzazione delle scorte ricambi. Con questo sistema modulare si richiedono solo 4 grandezze di supporto per 36 modelli di pompe. L'ancoraggio alla piastra di base effettuato attraverso i piedi del corpo ed il giunto con spaziatore, permettono un facile smontaggio del rotore completo, senza disturbare l'allineamento del gruppo e senza scollegare tubazioni e motore. La costruzione standard prevede flange UNI 2223-2229 PN 16. Su richiesta si eseguono forature UNI PN 25, ANSI 150 RF o altri standard.

OPTIONAL CONFIGURATIONS

Following optional configurations, according to the service required, can be provided: semi open impeller for abrasive and high viscosity liquids, for liquids with suspended solids that can clog the impeller. Inducer to decrease the NPSH required value. Heated casing and stuffing box when the pumped liquid needs a working temperature constantly higher than that of the environment temperature. Cooled stuffing box for cooling the seal. Heavy duty service bearings when the working conditions overstress the bearing.

Bearing cooling for high temperature. On request constant level oiler - Purge oil mist - Oil labyrinth seals

VARIANTI COSTRUTTIVE

Per meglio rispondere alle diverse esigenze dei servizi sono previste le seguenti varianti costruttive: girante semi-aperta per liquidi abrasivi, liquidi contenenti corpi solidi, liquidi ad alto grado di viscosità, liquidi che possono otturare i canali della girante. Inducer per abbassare il valore di NPSH richiesto quando se ne presenti la necessità. Riscaldamento corpo e cassastoppa per liquidi che richiedono una temperatura di esercizio costantemente superiore alla temperatura ambiente. Raffreddamento cassastoppa per raffreddare la tenuta. Supporto rinforzato quando le condizioni di lavoro sollecitano particolarmente i cuscinetti. Raffreddamento cuscinetti per alte temperature di servizio. A richiesta: oliatore a livello costante, lubrificazione purge oil mist, tenute per olio a labirinto.

SEALS

The stuffing box dimension allows the interchangeability between packing and standard mechanical seals. The standard construction uses mechanical seal according to DIN; it is also possible to fit every kind of mechanical seal. Standard mechanical seal flushing is realized with internal recirculation from pressure side to seal chamber. It is still possible to realize every kind of flushing line in an execution similar to API 610 standard.

TENUTE

La cassastoppa permette l'intercambiabilità della baderna con tenute meccaniche standard. Le tenute meccaniche sono standardizzate secondo le norme DIN, ma è possibile l'installazione di qualsiasi altro tipo di tenuta quale esterna, doppia o in tandem. Il flussaggio standard delle tenute è realizzato tramite circolazione interna tra la zona di mandata e la cassastoppa. È possibile realizzare qualunque linea di flussaggio simile agli schemi API 610.

CONSTRUCTION MATERIALS

Standard constructions are in cast iron, carbon steel, stainless steel, on request we can realize other metallurgic combinations.

MATERIALI DI COSTRUZIONE

Sono previste costruzioni standard in ghisa, acciaio al carbonio, acciaio inox; su richiesta sono realizzabili altre metallurgie costruttive.

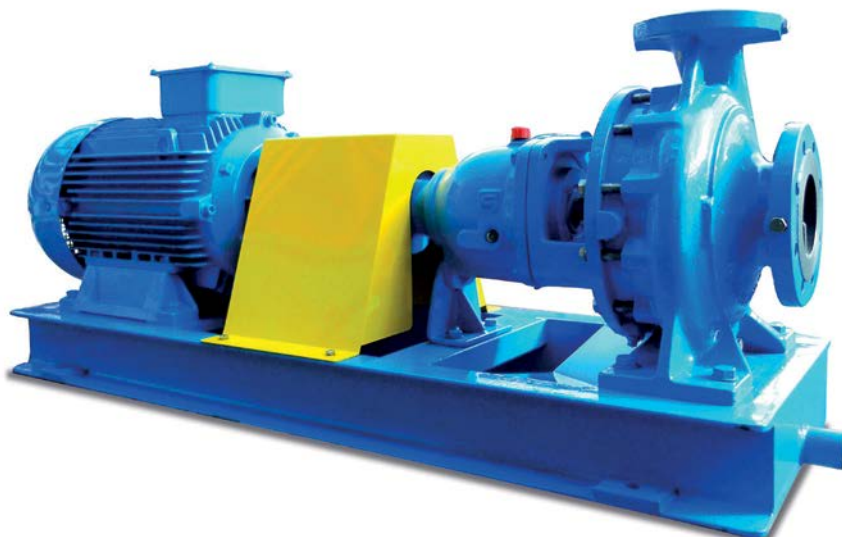

coupling and baseplate version
versione con giunto e basamento

BARE SHAFT VERSION
VERSIONE AD ASSE NUDO



closed impeller
girante chiusa



open impeller
girante aperta

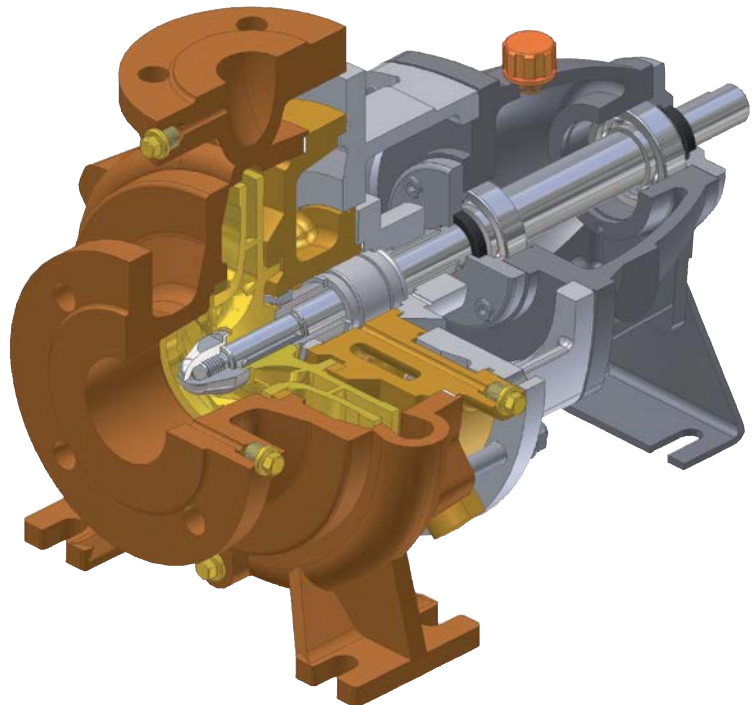

INTERCHANGEABILITY INTERCAMBIABILITÀ	
MODELS <i>MODELLI</i>	36
CASINGS <i>CORPI</i>	36
IMPELLERS <i>GIRANTI</i>	36
SHAFTS <i>ALBERI</i>	4
BEARING BRACKETS <i>SUPPORTI</i>	4
COVERS <i>COPERCHI</i>	30
MECHANICAL SEALS <i>TENUTE MECCANICHE</i>	4

MATERIALS <i>MATERIALI</i>	MAX. WORKING PRESSURE <i>PRESSIONE MAX. ESERCIZIO</i>
CAST IRON <i>GHISA</i>	16 bar
STAINLESS STEEL, BRONZE, SPECIAL ALLOYS <i>ACCIAIO INOX, BRONZO, LEGHE SPECIALI</i>	20 bar
NOTE: SPECIAL EXECUTIONS EXCEEDING THE ABOVE LIMITS AVAILABLE ON REQUEST <i>NOTA: ESECUZIONI SPECIALI AL DI FUORI DEI LIMITI SOPRAESPOSTI REALIZZATE SU RICHIESTA</i>	

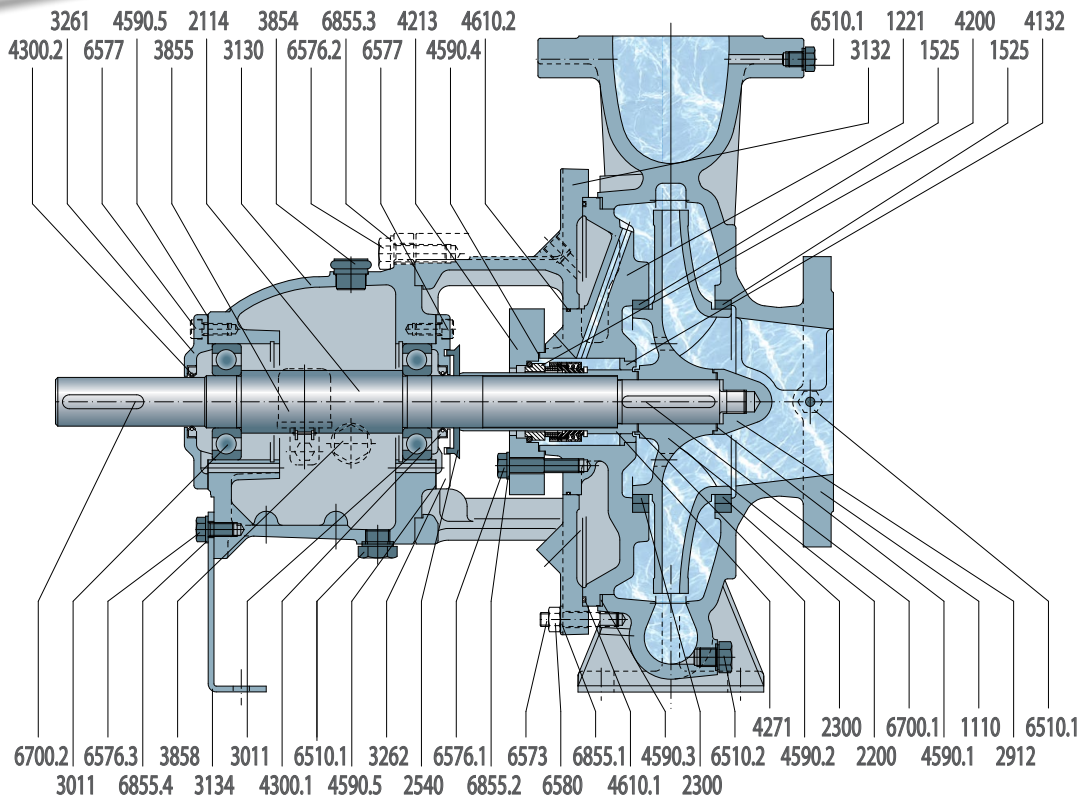

LONGITUDINAL SECTION

SEZIONE LONGITUDINALE

Pos	Description Descrizione
1110	Pump casing <i>Corpo pompa</i>
1221	Casing cover <i>Coperchio del corpo</i>
1525	Wear ring <i>Anello di usura</i>
2114	Pump shaft <i>Albero della pompa</i>
2200	Impeller <i>Girante</i>
2300	Impeller wear ring <i>Anello di usura girante</i>
2540	Deflector <i>Deflettore</i>
2912	Impeller nut <i>Dado girante</i>
3011	Radial ball bearing <i>Cuscinetto radiale</i>
3130	Bearing bracket <i>Supporto doppio</i>
3132	Bearing bracket lantern <i>Lanterna del supporto</i>
3134	Support foot <i>Piede del supporto</i>
3261	Bearing cover <i>Coperchio supporto</i>
3262	Bearing cover <i>Coperchio supporto</i>
3854	Oil filler plug <i>Tappo per l'olio</i>
3855	Constant level oiler <i>Oliatore a livello costante</i>
3858	Oil level <i>Spia dell'olio</i>
4132	Neck bush <i>Boccola di fondo</i>
4200	Mechanical seal <i>Tenuta meccanica</i>
4213	Mechanical seal cover <i>Coperchio per tenuta</i>
4271	Shaft sleeve <i>Camicia d'albero</i>
4300.1	Radial shaft seal <i>Anello di tenuta</i>

Pos	Description Descrizione
4300.2	Radial shaft seal <i>Anello di tenuta</i>
4590.1	Gasket <i>Guarnizione</i>
4590.2	Gasket <i>Guarnizione</i>
4590.3	Gasket <i>Guarnizione</i>
4590.4	Gasket <i>Guarnizione</i>
4590.5	Gasket <i>Guarnizione</i>
4610.1	O-Ring <i>O-Ring</i>
4610.2	O-Ring <i>O-Ring</i>
6510.1	Plug <i>Tappo</i>
6510.2	Plug <i>Tappo</i>
6573	Stud <i>Prigioniero</i>
6576.1	Screw <i>Vite</i>
6576.2	Screw <i>Vite</i>
6576.3	Screw <i>Vite</i>
6577	Screw <i>Vite</i>
6580	Nut <i>Dado</i>
6700.1	Key <i>Chiavetta</i>
6700.2	Key <i>Chiavetta</i>
6855.1	Washer <i>Rosetta</i>
6855.2	Washer <i>Rosetta</i>
6855.3	Washer <i>Rosetta</i>
6855.4	Washer <i>Rosetta</i>

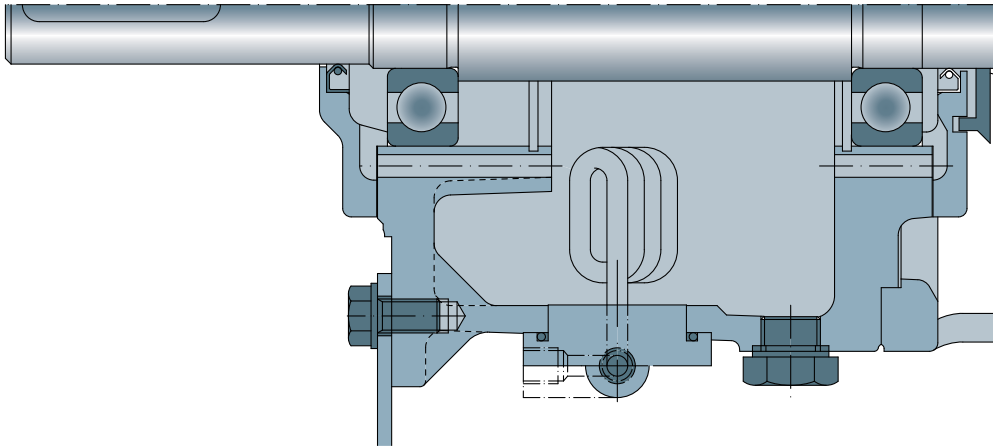

COOLED BEARINGS VERSION
VERSIONE CON SUPPORTO RAFFREDDATO

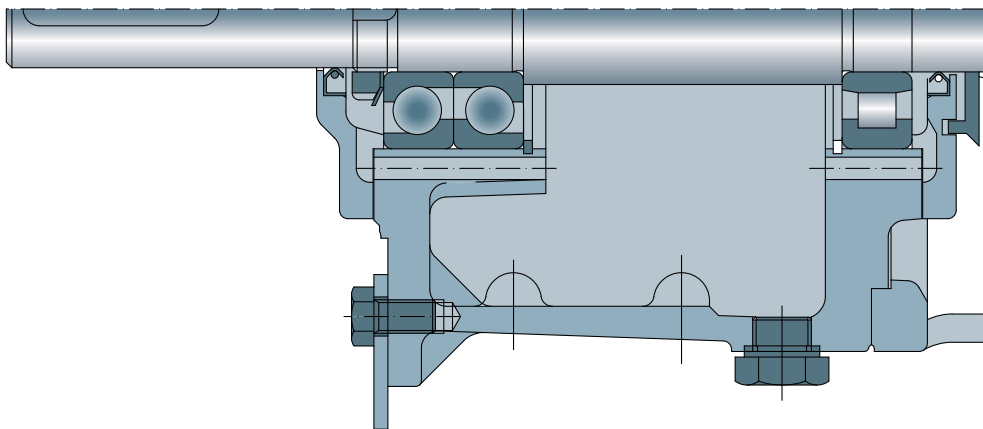

HEAVY DUTY BEARINGS VERSION
VERSIONE CON CUSCINETTI RINFORZATI

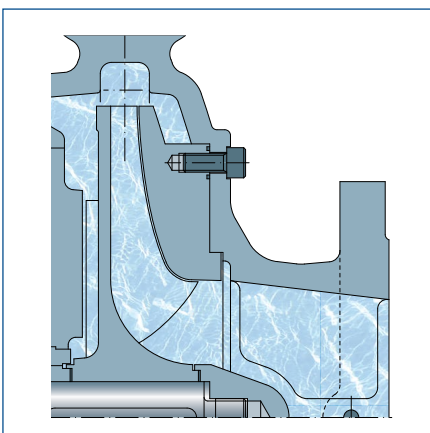

OPEN IMPELLER VERSION
VERSIONE A GIRANTE APERTA

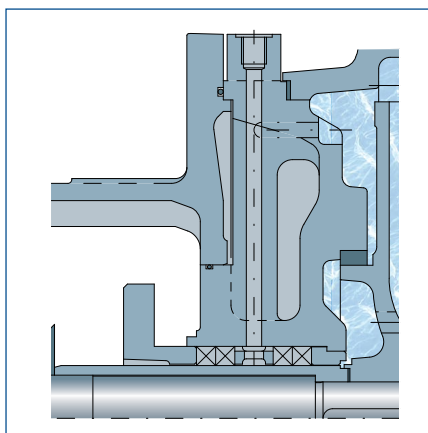

SOFT PACKING VERSION
VERSIONE TENUTA A BADERNA

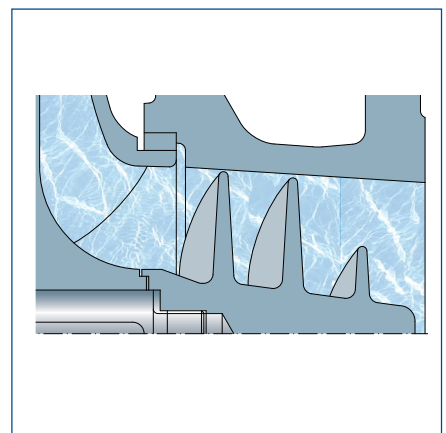

INDUCER
INDUCER



FLANGE: UNI - PN16
ANSI 150RF

FLANGIA: UNI - PN16
ANSI 150RF

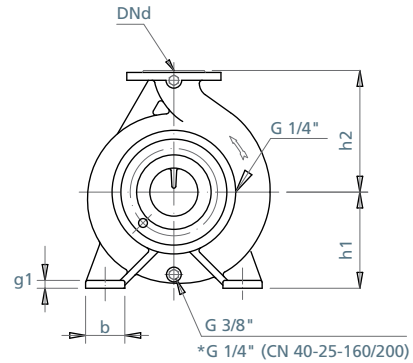
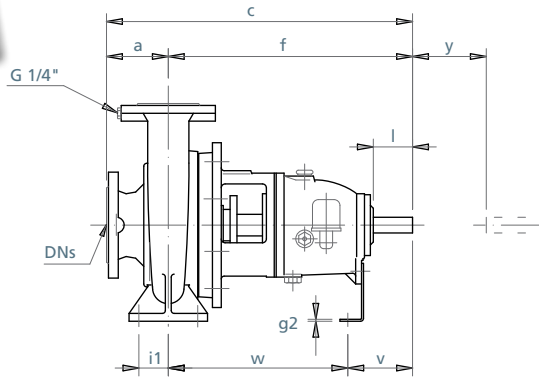

y: MINIMUM DIMENSION
FOR DISMANTLING WITHOUT
REMOVING THE MOTOR

y: MISURA MINIMA PER LO
SMONTAGGIO SENZA
TOGLIERE IL MOTORE

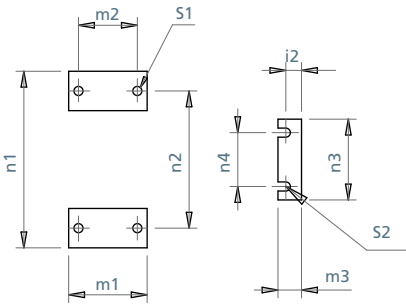

SHAFT END
ESTREMITÀ D'ALBERO

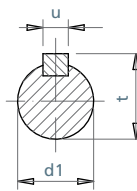

KEY ACCORDING TO UNI 6604
CHIAVETTA SECONDO UNI 6604

PUMP SIZE GRANDEZZA POMPA	BEARING BRACKET SIZE GRANDEZZA SUPPORTO	PUMP DIMENSIONS DIMENSIONI POMPA																	SHAFT END ESTREMITÀ D'ALBERO					FOUNDATION BOLTS BULLONI DI FONDAZIONE								WEIGHT (KG) PESO (KG)	
		DNA	DNM	a	b	c	f	g1	g2	h1	h2	h	m1	m3	n1	n3	d1 kØ	l	t	u	y	i1	i2	m2	n2	n4	s1	s2	v	w	Cast Iron Ghisa	Steel Acciaio	
*40-25-160	24	40	25	63	50	448	385	12	8	112	160	272	100	50	220	150	24	50	27	8	140	35	25	70	180	110	12	14	100	285	37	40	
*40-25-200	24	40	25	80	50	465	385	15	8	160	180	340	100	50	240	150	24	50	27	8	140	35	25	70	190	110	14	14	100	285	45	48	
50-32-125	24	50	32	80	50	465	385	12	8	112	140	252	100	50	190	150	24	50	27	8	140	35	25	70	140	110	14	14	100	285	37	40	
50-32-160	24	50	32	80	50	465	385	14	8	132	160	292	100	50	240	150	24	50	27	8	140	35	25	70	190	110	14	14	100	285	42	45	
50-32-200	24	50	32	80	50	465	385	14	8	160	180	340	100	50	240	150	24	50	27	8	140	35	25	70	190	110	14	14	100	285	50	55	
50-32-250	32	50	32	100	65	600	500	16	8	180	225	405	125	50	320	150	32	80	35	10	140	47,5	25	95	250	110	14	14	130	370	85	87	
65-50-125	24	65	50	80	50	465	385	14	8	112	140	252	100	50	190	150	24	50	27	8	140	35	25	70	140	110	14	14	100	285	38	45	
65-50-160	24	65	50	80	50	465	385	14	8	132	160	292	100	50	240	150	24	50	27	8	140	35	25	70	190	110	14	14	100	285	43	50	
65-40-200	24	65	40	100	50	485	385	14	8	160	180	340	100	50	265	150	24	50	27	8	140	35	25	70	212	110	14	14	100	285	53	60	
65-40-250	32	65	40	100	65	600	500	16	8	180	225	405	125	50	320	150	32	80	35	10	140	47,5	25	95	250	110	14	14	130	370	89	95	
65-40-315	32	65	40	125	65	625	500	18	8	200	250	450	125	50	345	150	32	80	35	10	140	47,5	25	95	280	110	14	14	130	370	111	115	
80-65-125	24	80	65	100	50	485	385	14	8	132	160	292	100	50	240	150	24	50	27	8	140	35	25	70	190	110	14	14	100	285	46	48	
80-65-160	24	80	65	100	50	485	385	14	8	160	180	340	100	50	265	150	24	50	27	8	140	35	25	70	212	110	14	14	100	285	47	55	
80-50-200	24	80	50	100	50	485	385	14	8	160	200	360	100	50	265	150	24	50	27	8	140	35	25	70	212	110	14	14	100	285	56	60	
80-50-250	32	80	50	125	65	625	500	16	8	180	225	405	125	50	320	150	32	80	35	10	140	47,5	25	95	250	110	14	14	130	370	92	105	
80-50-315	32	80	50	125	65	625	500	18	8	225	280	505	125	50	345	150	32	80	35	10	140	47,5	25	95	280	110	14	14	130	370	116	120	
100-80-125	24	100	80	100	65	485	385	14	8	160	180	340	125	50	280	150	24	50	27	8	140	47,5	25	95	212	110	14	14	100	285	55	58	
100-80-160	32	100	80	100	65	600	500	16	8	160	200	360	125	50	280	150	32	80	35	10	140	47,5	25	95	212	110	14	14	130	370	68	75	
100-65-200	32	100	65	100	65	600	500	16	8	180	225	405	125	50	320	150	32	80	35	10	140	47,5	25	95	250	110	14	14	130	370	80	85	
100-65-250	32	100	65	125	80	625	500	18	8	200	250	450	160	50	360	150	32	80	35	10	140	60	25	120	280	110	18	14	130	370	103	110	
100-65-315	42	100	65	125	80	655	530	18	8	225	280	505	160	50	400	150	42	110	45	12	140	60	25	120	315	110	18	14	160	370	133	140	
125-80-160	32	125	80	125	65	625	500	16	8	180	225	405	125	50	320	150	32	80	35	10	140	47,5	25	95	250	110	14	14	130	370	80	85	
125-80-200	32	125	80	125	65	625	500	16	8	180	250	430	125	50	345	150	32	80	35	10	140	47,5	25	95	280	110	14	14	130	370	88	95	
125-80-250	32	125	80	125	80	625	500	18	8	225	280	505	160	50	400	150	32	80	35	10	140	60	25	120	315	110	18	14	130	370	110	120	
125-80-315	42	125	80	125	80	655	530	18	8	250	315	565	160	50	400	150	42	110	45	12	140	60	25	120	315	110	18	14	160	370	136	146	
125-80-400	42	125	80	125	80	655	530	20	8	280	355	635	160	50	435	150	42	110	45	12	140	60	25	120	355	110	18	14	160	370	159	165	
125-100-200	32	125	100	125	80	625	500	16	8	200	280	480	160	50	360	150	32	80	35	10	140	60	25	120	280	110	18	14	130	370	103	110	
125-100-250	42	125	100	140	80	670	530	18	8	225	280	505	160	50	400	150	42	110	45	12	140	60	25	120	315	110	18	14	160	370	130	135	
125-100-315	42	125	100	140	80	670	530	18	8	250	315	565	160	50	400	150	42	110	45	12	140	60	25	120	315	110	18	14	160	370	150	160	
125-100-400	42	125	100	140	100	670	530	20	8	280	355	635	200	50	500	150	42	110	45	12	140	75	25	150	400	110	22	14	160	370	183	196	
150-125-250	42	150	125	140	80	670	530	18	8	250	355	605	160	50	400	150	42	110	45	12	140	60	25	120	315	110	18	14	160	370	150	164	
150-125-315	42	150	125	140	100	670	530	20	8	280	355	635	200	50	500	150	42	110	45	12	140	75	25	150	400	110	22	14	160	370	164	176	
150-125-400	42	150	125	140	100	670	530	20	8	315	400	715	200	50	500	150	42	110	45	12	140	75	25	150	400	110	22	14	160	370	190	210	
200-150-250	42	200	150	160	100	690	530	20	8	280	375	655	200	50	500	150	42	110	45	12	140	75	25	150	400	110	22	14	160	370	195	230	
200-150-315	48	200	150	160	100	830	670	22	8	315	400	715	200	65	550	180	48	110	51	14	180	75	32	150	450	160	22	18	170	500	250	270	
200-150-400	48	200	150	160	100	830	670	22	8	315	450	765	200	65	550	180	48	110	51	14	180	75	32	150	450	160	22	18	170	500	278	293	

* PUMPS NOT COMPLYING WITH ISO 2858 STANDARDS POMPE NON NORMALIZZATE ISO 2858

PERFORMANCES PRESTAZIONI

1450 RPM

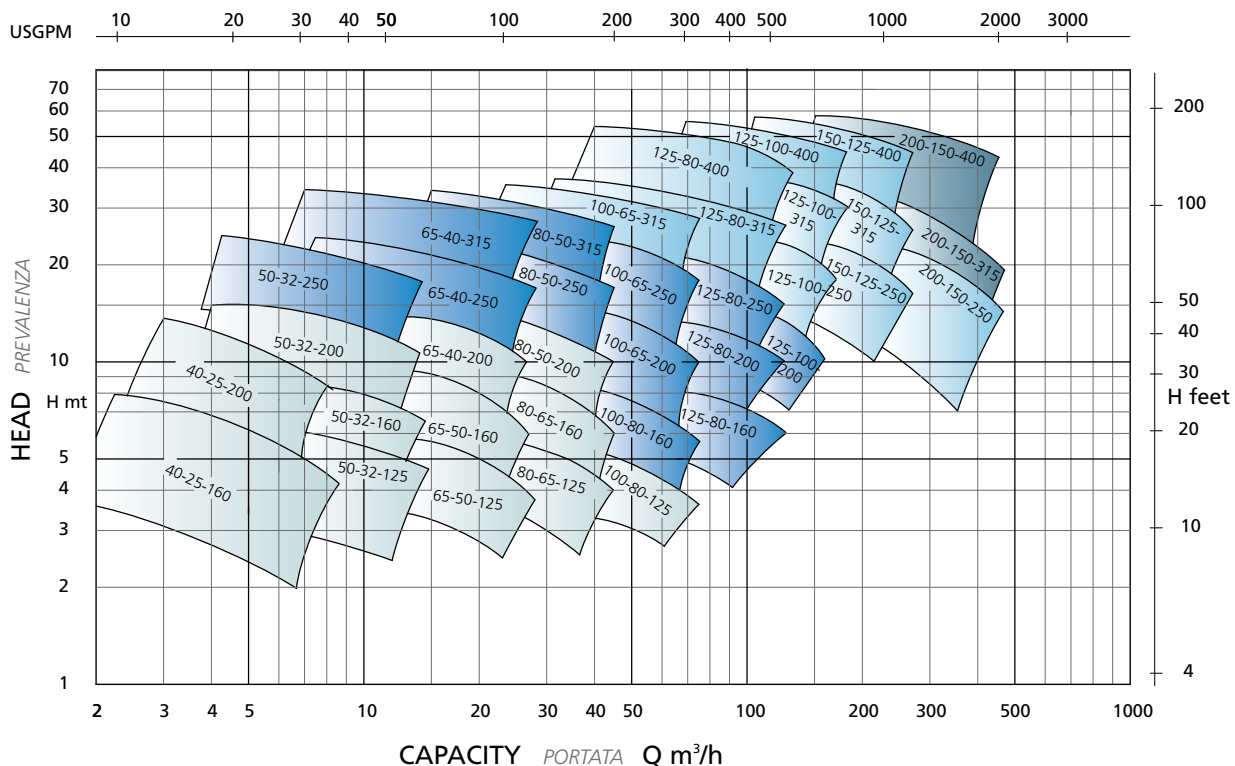

PERFORMANCES PRESTAZIONI

2900 RPM

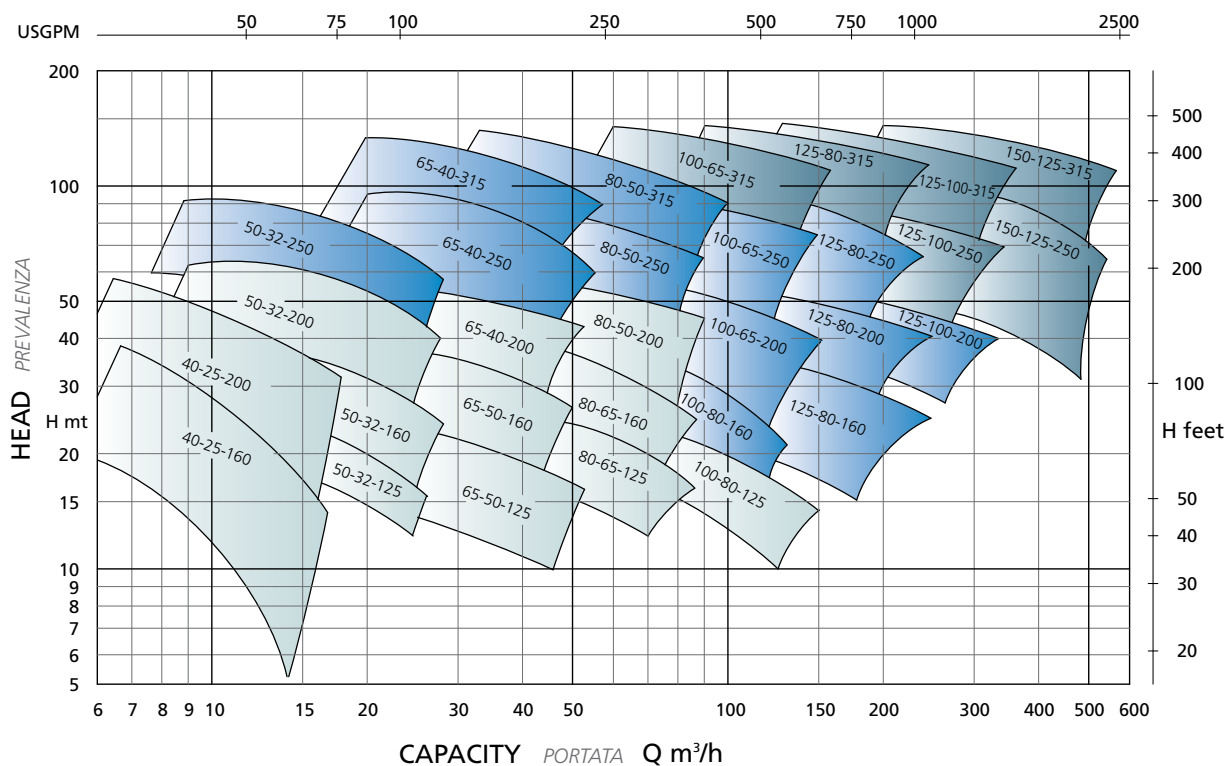

Operating diagrams at 60 Hz for CN pumps also available. Contact our sales dept.
 I campi di lavoro delle pompe CN sono disponibili anche a 60 Hz. Contattare il nostro ufficio.



POMPE GARBARINO S.p.A.

Headquarters:

Via Marengo, 44 - 15011 Acqui Terme (AL) - Italy - Tel. +39 0144.388671 - Fax +39 0144.55260

E-mail: info@pompegarbarino.it

Milan Branch:

Viale Andrea Doria, 31 - 20124 Milano - Italy - Tel. +39 02.67070037 - Fax +39 02.67070097

www.pompegarbarino.com