

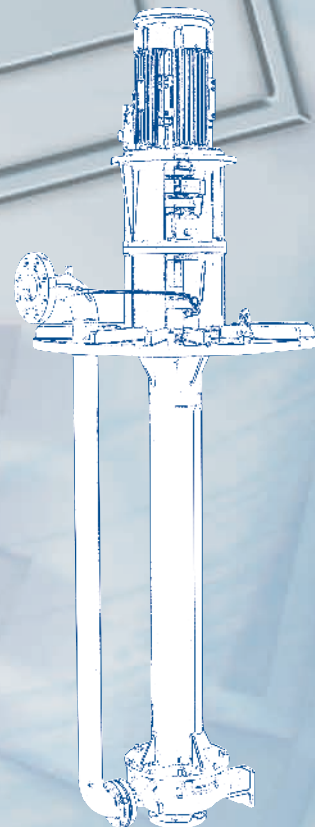

GARBARINO®

VS

**Vertically suspended line-shaft centrifugal pumps
Pompe centrifughe sospese ad asse verticale**





VS

VERTICALLY SUSPENDED LINE-SHAFT CENTRIFUGAL PUMPS

*POMPE CENTRIFUGHE SOSPESSE
AD ASSE VERTICALE*

DESCRIPTION

The VS serie pumps are suspended vertical line-shaft, single stage pumps with base plate. The main components (casing, cover, pump flanges etc.) are based on our MU or MCA series.

DESCRIZIONE

Le pompe serie VS sono pompe verticali monostadio immerse a linea d'asse con piastra di base. Il corpo e la girante derivano dalle pompe serie MU o serie MCA.

APPLICATIONS

The VS serie pumps are used to pump clean or dirty fluids that may contain suspended abrasive materials. They are specially useful for many industrial processes, supply drainage, etc.. Thanks to their versatility and material diversification, the VS series handle and pump a wide range of fluids.

APPLICAZIONI

Le pompe serie VS vengono impiegate per il pompaggio di acque di drenaggio da vasche di raccolta, recupero condensa, trasferimenti emulsioni e liquidi chimicamente aggressivi, trattamento acque o fanghi, ecc. Sono impiegate in tutti quelle applicazioni dove è necessario installare le pompe direttamente sulle vasche o sui serbatoi metallici.

VERSIONS

The standard pumps of the VS series are manufactured with closed impeller and rectangular base plate. The range is wide and includes different impeller options and base plate shapes. They can be adapted to any type and size of tanks, as each pump is available in 60 different models and shaft lengths up to 7,5 m.

VERSIONI

Le pompe serie VS standard sono costruite con girante chiusa radiale o aperta arretrata ad un ingresso ed uno stadio. La tipologia è vasta e prevede diversi diametri di giranti e forme di piastra di base. Le pompe possono essere adattate ad ogni tipo e grandezza di serbatoio / vasca in quanto la serie VS è disponibile in 60 modelli diversi e con qualsiasi lunghezza fino a 7,5 metri.

MANUFACTURING

The remarkably sturdy design of the VS series pumps offers many significant features, carefully chosen and calculated, making these pumps comply with the most demanding specifications.

COSTRUZIONE

L'adozione delle idrauliche MU ed MCA garantisce rapidità di fornitura ed una scorta di ricambi ridotta. La spinta assiale viene equilibrata mediante le palettature posteriori per la serie MCA ed anelli con fori di bilanciamento per la serie MU. (Dimensionamento alberi secondo API 610)

MOTOR FRAME AND BEARING BOX: Motor frame ensures overall stiffness and motor support. Alternative solutions with grease lubricated dual ball bearing for standard execution and with bearing cooling chamber for high temperature fluids are available.

LANTERNA MOTORE E SUPPORTO: La lanterna motore, assicura completa solidità e sopportazione del motore. L'esecuzione standard prevede la lubrificazione a grasso dei due cuscinetti a sfera reggispinna.

BASE PLATE: Rectangular base plate in standard execution. Optional versions with circular base plate, according to DIN, ANSI or on drawing measures particularly useful for installation in cylindric tanks are also available. The over thickened base plate is calculated to support the overhung and the assembly stresses.

PIASTRA DI BASE:
L'esecuzione standard è con piastra di base rettangolare. Sono disponibili versioni con piastra circolare per installazione su bocchelli flangiati secondo norme DIN, ANSI, JIS o misure particolari per installazione secondo il disegno del cliente. La piastra di base è sovradimensionata per sopportare la parte a sbalzo e le sollecitazioni alle massime prestazioni della pompa.

BUSHING AND TIGHTNESS:

The pump standard sealing on mounting plate is by means of a lip sealing ring. Alternatively also the following versions are available: soft packing - mechanical seal. The standard bushes are lubricated by the pumped fluid. They can also be lubricated by grease, oil, water or other fluids through an external device. Bush grooves ensure the lubrication.

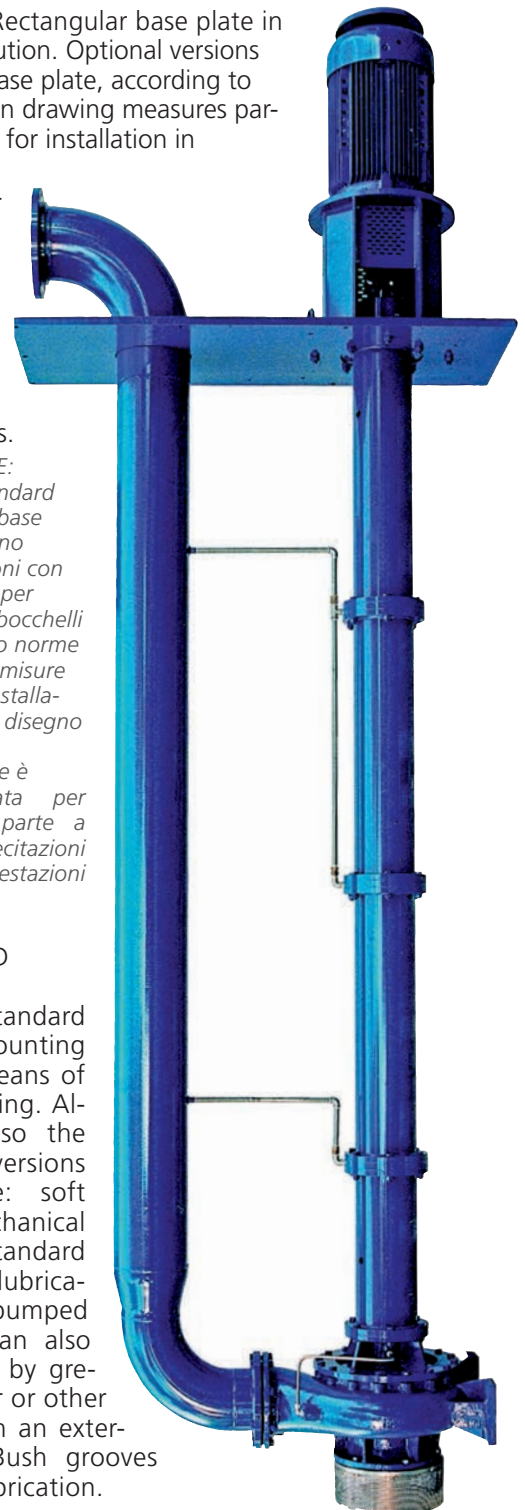

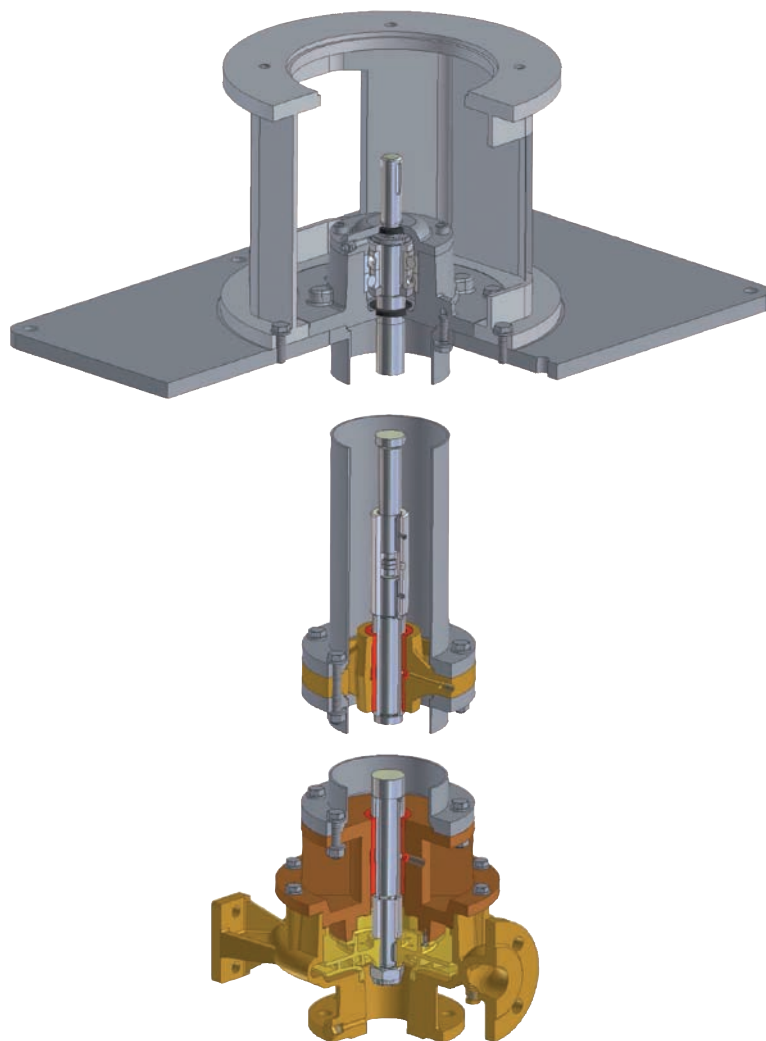

BARE SHAFT VERSION

VERSIONE AD ASSE NUDO

BRONZINE E TENUTE: La tenuta standard della pompa, a livello della piastra di base, è ottenuta mediante anello di tenuta a labbro. Sono disponibili le seguenti altre versioni:

- tenuta a baderna

- tenuta meccanica: semplice o doppia "back to back" con flussaggio esterno. Le bronzine nella versione standard sono lubrificate dal liquido pompato. Possono essere anche lubrificate dall'esterno con grasso, acqua o altri fluidi secondo l'utilizzo.

AXIAL COUPLING AND ADJUSTMENT: The two-half flexible couplings between the motor and the pump prevent the motor from pump stresses. Alignment between the pump and the motor is not required since the coupling lantern is designed to avoid misalignment. The two sections of the pump shaft are coupled by means of an intermediate coupling.

ACCOPPIAMENTI ASSIALI E REGOLAZIONI: I due semigiunti flessibili tra motore e pompa garantiscono che non vengano trasmesse al motore le sollecitazioni della pompa stessa. L'allineamento tra pompa e motore non è necessario poiché la lanterna di accoppiamento è costruita in modo da evitare disallineamenti. L'accoppiamento tra due sezioni dell'albero della pompa è ottenuto mediante un giunto intermedio. La coppia motrice è trasmessa tramite linguette.

Nell'esecuzione con giunto rigido la pompa è in versione back pull out per lo smontaggio dei cuscinetti reggispira.

PIPES AND FLANGES: Flanged column pipe and delivery pipe of VS series are made in welded steel. The discharge flange is UNI-PN 10 standard with "RF" finishing.

Maximum length of each column pipe is approx. 1250 mm., according to the pump size. The flanged pipes are connected to each other through an intermediate bearing housing the bush to guide the pump shaft. The column pipe has holes drilled in its lower part, reducing vortex effect once the fluid level decreases.

TUBI E FLANGE: I tubi guida portanti e i tubi prementi delle pompe serie VS sono costruiti in acciaio saldato con flange nella versione standard. La flangia di mandata è standard UNI PN 10, con superficie "RF".

La massima lunghezza di ogni tubo guida è circa 1250 mm e viene dimensionata in funzione della grandezza pompa. I tubi guida flangiati sono uniti da un supporto intermedio che alloggia la bronzina per una perfetta guida dell'albero senza vibrazioni.

PUMP SUCTION: The wet well standard version is with flanged filter. Alternative executions with suction bell or feeder line for wet well or with 90° elbow pipe with lower support for dry well, are available.

ASPIRAZIONE POMPA: La versione standard prevede un filtro flangiato. Altre versioni prevedono aspirazione a campana o tronchetto di prolunga.

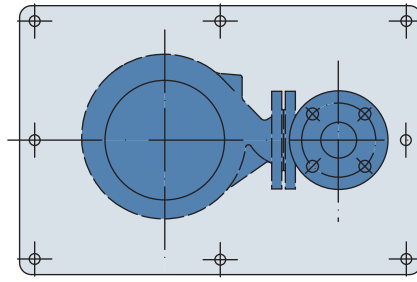

Standard construction: regular base plate
Piastra standard

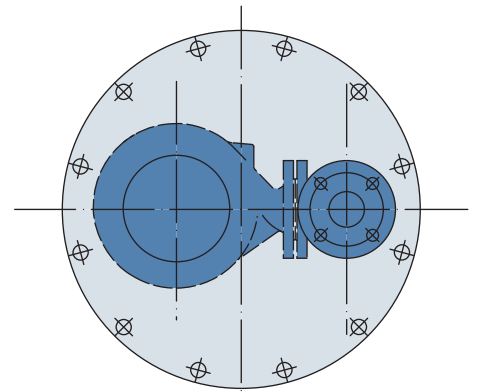

Special flange base plate
Piastra speciale

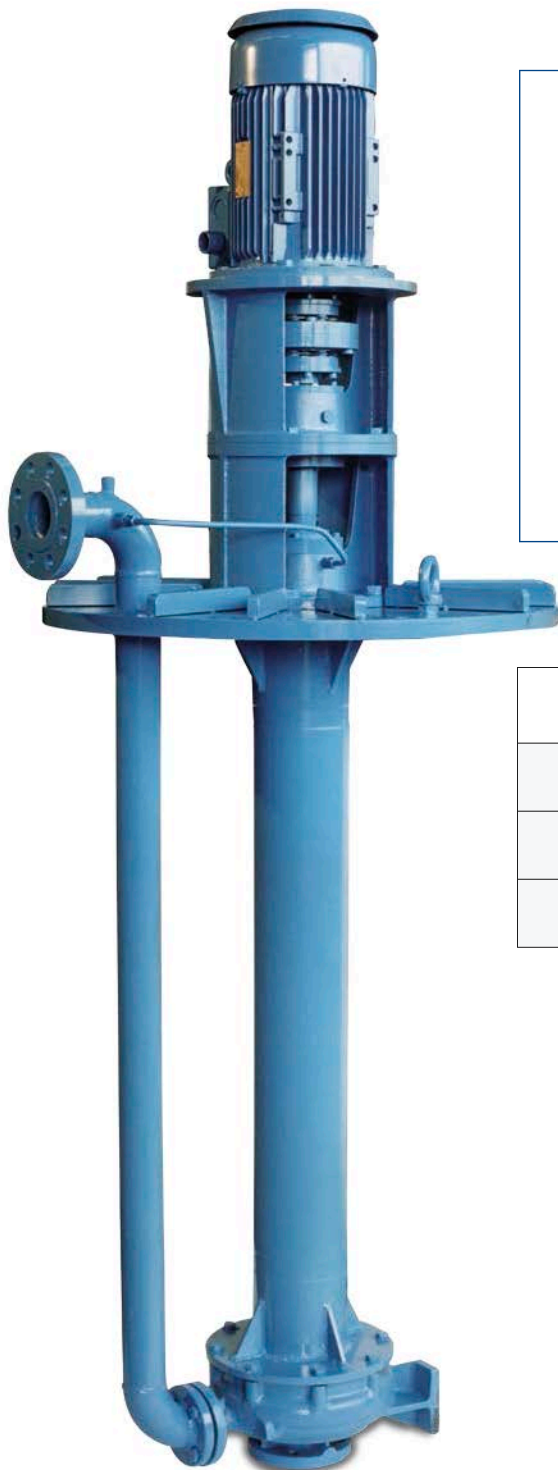

closed impeller
girante chiusa
(MU - VS)



open impeller
girante aperta
(MCA - VS)

MATERIALS <i>MATERIALI</i>	MAX. WORKING PRESSURE <i>PRESSIONE MAX. ESERCIZIO</i>
CAST IRON <i>GHISA</i>	10 bar
STAINLESS STEEL, BRONZE, SPECIAL ALLOY <i>ACCIAIO INOX, BRONZO, LEGHE SPECIALI</i>	16 bar
NOTE: SPECIAL EXECUTIONS EXCEEDING THE ABOVE LIMITS AVAILABLE ON REQUEST <i>NOTA: ESECUZIONI SPECIALI AL DI FUORI DEI LIMITI SOPRAESPOSTI REALIZZATE SU RICHIESTA</i>	

INTERCHANGEABILITY <i>INTERCAMBIABILITÀ</i>	
MODELS <i>MODELLI</i>	64
CASINGS <i>CORPI</i>	62
IMPELLERS <i>GIRANTI</i>	62
LINE-SHAFTS <i>LINEA D'ASSE</i>	4
BEARING BRACKETS <i>SUPPORTI</i>	4

MU - VS

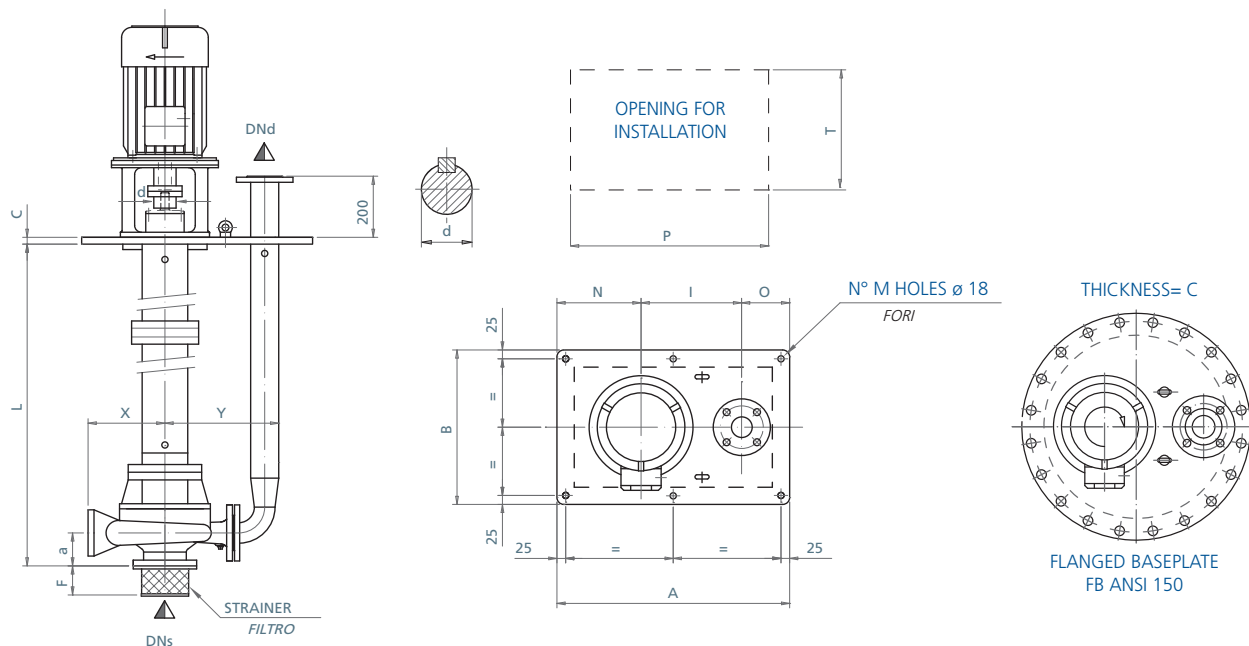

PUMP TYPE TIPO POMPA	SIZE GRANDEZZA	OVERALL DIMENSIONS DIMENSIONI D'INGOMBRO														MAX LENGHT (L) FOR EACH INTERMEDIATE SUPPORT MAX. LUNGH. (L) PER NUMERO DI SUPPORTI INTERMEDI					FB				
		DNs	DNd	a	d	l	N	O	A	B	C	M	P	T	F	X	Y	MIN	0	1		2	3	4	5
MU-VS	24	25	32	63	32	280	300	120	700	550	20	6	550	400	100	112	301	500	1061	2311	3561	4811	6061	7311	20"
25-200	32	40	32	80	32	300	275	125	700	550	20	6	550	400	150	160	321	500	1199	2449	3699	4949	6199	7449	24"
32-160	32	50	40	80	32	300	275	125	700	550	20	6	550	400	150	132	324	500	1199	2449	3699	4949	6199	7449	22"
32-200	32	50	40	80	32	320	300	130	750	550	20	6	600	400	150	160	344	500	1199	2449	3699	4949	6199	7449	24"
32-250	32	50	40	110	32	365	300	135	800	550	20	6	650	400	150	180	389	500	1229	2479	3729	4979	6229	7479	26"
40-160	32	65	50	80	32	320	300	130	750	550	20	6	600	400	150	132	344	500	1299	2449	3699	4949	6199	7449	24"
40-200	32	65	50	100	32	320	300	130	750	550	20	6	600	400	150	160	350	500	1219	2469	3719	4969	6219	7469	26"
40-250	32	65	50	100	32	365	300	135	800	550	20	6	650	400	150	180	396	500	1219	2469	3719	4969	6219	7469	28"
50-160	32	65	65	100	32	320	300	130	750	550	20	6	600	400	150	160	356	500	1219	2469	3719	4969	6219	7469	24"
50-200	32	65	65	100	32	340	300	160	800	550	20	6	650	400	150	160	378	500	1219	2469	3719	4969	6219	7469	26"
50-250	32	65	65	100	32	365	300	135	800	550	20	6	650	400	150	180	403	500	1219	2469	3719	4969	6219	7469	28"
65-160	32	80	80	100	32	310	300	140	750	550	20	6	600	400	150	160	348	500	1219	2469	3719	4969	6219	7469	-
65-200	32	80	80	100	32	335	300	165	800	550	20	6	650	400	150	180	379	500	1219	2469	3719	4969	6219	7469	-
80-160	32	100	100	125	32	355	300	145	800	550	20	6	650	400	150	180	412	500	1244	2494	3744	4994	6244	7499	-
40-315	32	65	50	125	32	350	300	150	800	650	20	6	650	500	150	200	380	600	1255	2505	3755	5005	6255	7505	-
50-315	32	65	65	125	32	390	350	160	900	650	20	6	750	500	150	225	428	600	1255	2505	3755	5005	6255	7505	-
65-250	32	80	80	100	32	360	300	140	800	600	20	6	650	450	150	200	404	600	1230	2480	3730	4980	6230	7480	-
65-315	32	80	80	125	32	390	350	160	900	600	20	6	750	450	150	225	434	600	1255	2505	3755	5005	6255	7505	-
65-400	32	80	80	125	32	465	350	135	950	750	20	6	800	600	150	250	509	600	1255	2505	3755	5005	6255	7505	-
80-200	32	100	100	125	32	380	300	170	850	600	20	6	700	450	150	180	437	600	1255	2505	3755	5005	6255	7505	-
80-250	32	100	100	125	32	410	300	140	850	600	20	6	700	450	150	200	467	600	1255	2505	3755	5005	6255	7505	-
80-315	32	100	100	125	32	440	350	160	950	600	20	6	800	450	150	250	497	600	1255	2505	3755	5005	6255	7505	-
100-200	32	125	125	125	32	450	300	200	950	600	20	6	800	450	150	200	520	600	1255	2505	3755	5005	6255	7505	-
100-250	32	125	125	140	32	450	350	200	1000	600	20	6	850	450	150	225	520	600	1270	2520	3770	5020	6270	7520	-
100-315	32	125	125	140	32	485	350	215	1050	600	20	6	900	450	150	250	554	600	1270	2520	3770	5020	6270	7520	-
125-250	32	150	150	140	32	565	350	185	1100	600	20	6	950	450	150	250	649	600	1270	2520	3770	5020	6270	7520	-
80-400	42	100	100	125	42	485	400	165	1050	750	25	8	900	600	150	280	542	700	1282	2532	3782	5032	6282	-	-
100-400	42	125	125	140	42	525	400	175	1100	750	25	8	950	600	150	280	595	700	1297	2547	3797	5047	6297	-	-
125-315	42	150	150	140	42	565	400	185	1150	700	25	8	1000	550	150	280	649	700	1297	2547	3797	5047	6297	-	-
125-400	42	150	150	140	42	610	450	190	1250	750	25	8	1100	600	150	315	694	700	1297	2547	3797	5047	6297	-	-
150-250	42	200	200	160	42	625	400	225	1250	750	25	8	1100	600	150	280	735	700	1317	2567	3817	5067	6317	-	-
150-315	42	200	200	160	42	650	400	250	1300	750	25	8	1150	600	150	280	760	700	1317	2567	3817	5067	6317	-	-
150-400	42	200	200	160	42	700	450	250	1400	850	25	8	1250	700	150	315	810	700	1317	2567	3817	5067	6317	-	-
200-250	42	200	250	180	42	755	450	245	1450	850	25	8	1300	700	150	355	892	700	1337	2587	3837	5087	6337	-	-
125-500	55	150	150	180	55	720	500	230	1450	1000	30	8	1300	850	200	400	904	800	1297	2547	3797	5047	6297	-	-
150-500	55	200	200	180	55	800	500	250	1550	1000	30	10	1400	850	200	400	909	800	1397	2629	3879	5129	6379	-	-
200-315	55	250	250	200	55	780	450	270	1500	900	30	10	1350	750	200	355	917	800	1395	2645	3895	5145	6395	-	-
200-400	55	250	250	200	55	830	450	270	1550	950	30	10	1400	800	200	355	966	800	1317	2567	3817	5067	6317	-	-
200-500	55	250	250	200	55	930	550	270	1750	1100	30	10	1600	950	200	455	1067	800	1399	2649	3899	5149	6399	-	-
250-250	55	300	300	250	55	965	500	285	1750	1000	30	10	1600	850	200	355	1171	800	1445	2695	3945	5195	6445	-	-
250-315	55	300	300	250	55	965	500	285	1750	1000	30	10	1600	850	200	400	1161	800	1445	2695	3945	5195	6445	-	-
250-400	55	300	300	225	55	1005	500	295	1800	1000	30	10	1650	850	200	375	1166	800	1420	2670	3920	5170	6420	-	-
250-500	55	300	300	280	55	1090	600	260	1950	1100	30	10	1800	950	200	475	1251	800	1420	2670	3920	5170	6420	-	-



MCA - VS

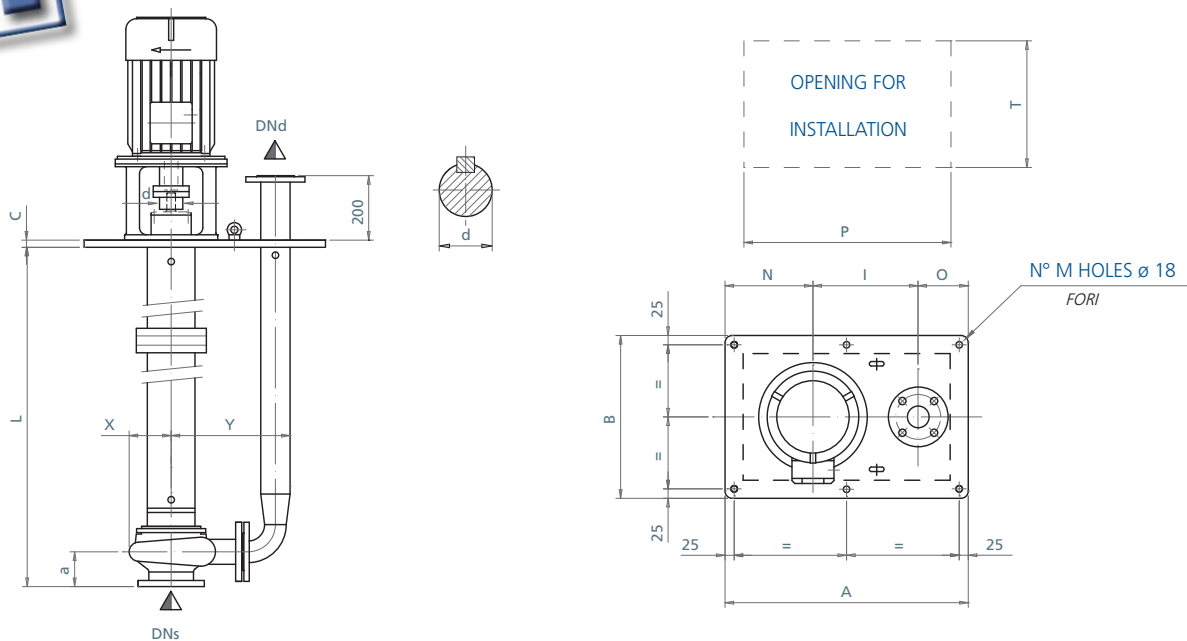

PUMP TYPE TIPO POMPA	SIZE GRANDEZZA	OVERALL DIMENSIONS DIMENSIONI D'INGOMBRO														MAX LENGHT (L) FOR EACH INTERMEDIATE SUPPORT MAX. LUNGH. (L) PER NUMERO DI SUPPORTI INTERMEDI						
		DNs	DNd	a	d	l	N	O	A	B	C	M	P	T	X	Y	0	1	2	3	4	5
MCA-VS																						
32-200	24	50	40	80	32	320	300	130	750	550	20	6	600	400	160	344	1121	2371	3621	4871	6121	7371
50-125	24	65	65	90	32	320	300	130	750	550	20	6	600	400	150	357	1122	2372	3622	4872	6122	7372
50-140	24	65	65	100	32	320	300	130	750	550	20	6	600	400	150	357	1194	2444	3694	4944	6194	7444
50-160	24	65	65	100	32	340	300	160	800	550	20	6	650	400	150	377	1194	2444	3694	4944	6194	7444
50-200	32	65	65	100	32	365	300	135	800	550	20	6	650	400	150	402	1194	2444	3694	4944	6194	7444
50-250	32	65	65	100	32	360	300	140	800	600	20	6	650	450	180	397	1194	2444	3694	4944	6194	7444
50-280	32	65	65	105	32	440	350	160	950	600	20	6	800	450	220	477	1213	2463	3713	4963	6213	7463
80-160	24	100	100	115	32	380	300	170	850	600	20	6	700	450	180	438	1224	2474	3724	4974	6224	7474
80-200	32	100	100	125	32	380	300	170	850	600	20	6	700	450	180	438	1240	2490	3740	4990	6240	7490
80-250	32	100	100	125	32	440	350	160	950	600	20	6	800	450	225	497	1245	2495	3745	4995	6245	7495
80-280	32	100	100	125	32	485	400	165	1050	650	20	6	900	500	250	543	1243	2493	3743	4993	6243	7493
80-335	42	100	100	125	42	485	400	165	1050	650	25	6	900	500	280	543	1265	2515	3765	5015	6265	7515
100-200	32	125	125	140	32	450	300	200	950	600	20	6	800	450	225	520	1270	2520	3770	5020	6270	7520
100-250	32	125	125	140	32	485	350	215	1050	600	20	6	900	450	225	556	1270	2520	3770	5020	6270	7520
100-280	42	125	125	140	42	525	400	175	1100	700	25	8	950	550	250	595	1290	2540	3790	5040	6290	7540
100-335	42	125	125	140	42	755	450	245	1450	750	25	8	1300	600	280	826	1290	2540	3790	5040	6290	7540
150-250	32	200	200	165	32	625	400	225	1250	700	20	8	1100	550	280	735	1320	2570	3820	5070	6320	7570
150-280	42	200	200	165	42	650	400	250	1300	750	25	8	1150	600	280	760	1340	2590	3840	5090	6340	7590
150-335	42	200	200	165	42	700	450	250	1400	750	25	8	1250	600	320	810	1340	2590	3840	5090	6340	7590

ONLY FOR : 1450-1750 RPM SOLO PER: 1450-1750 RPM

GR.32

GR.42



MCA-VS
LONGITUDINAL SECTION
 SEZIONE LONGITUDINALE

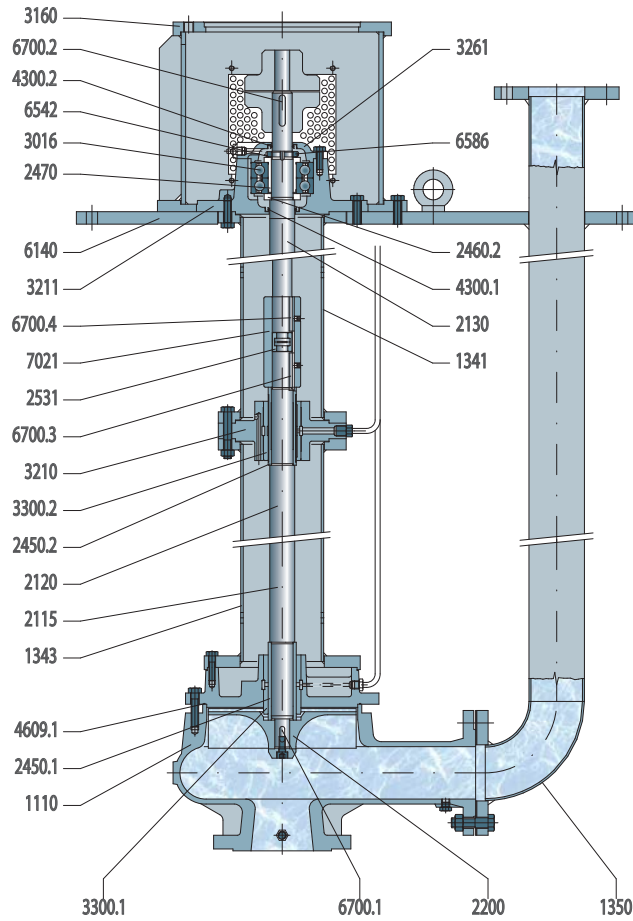

MU-VS
LONGITUDINAL SECTION
 SEZIONE LONGITUDINALE

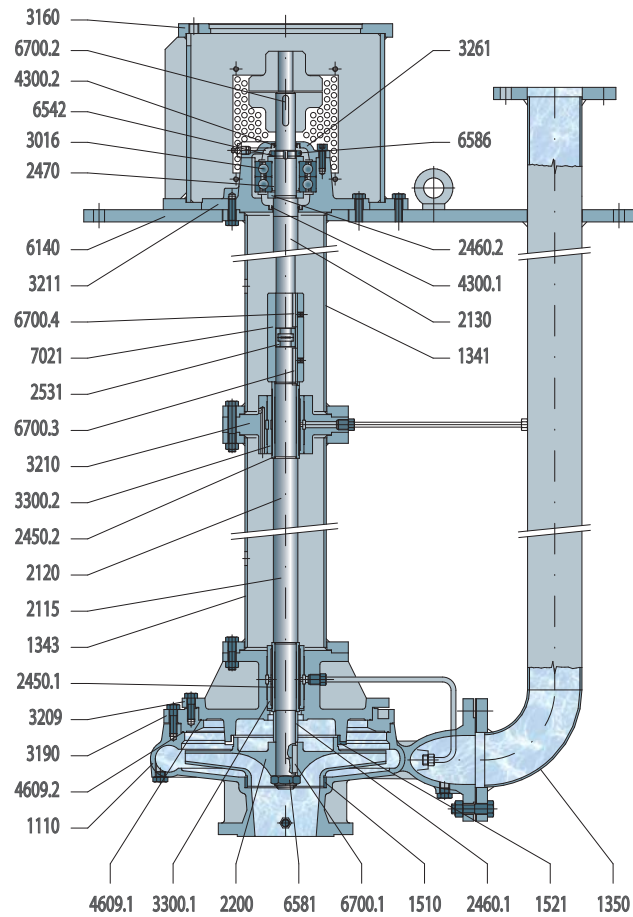

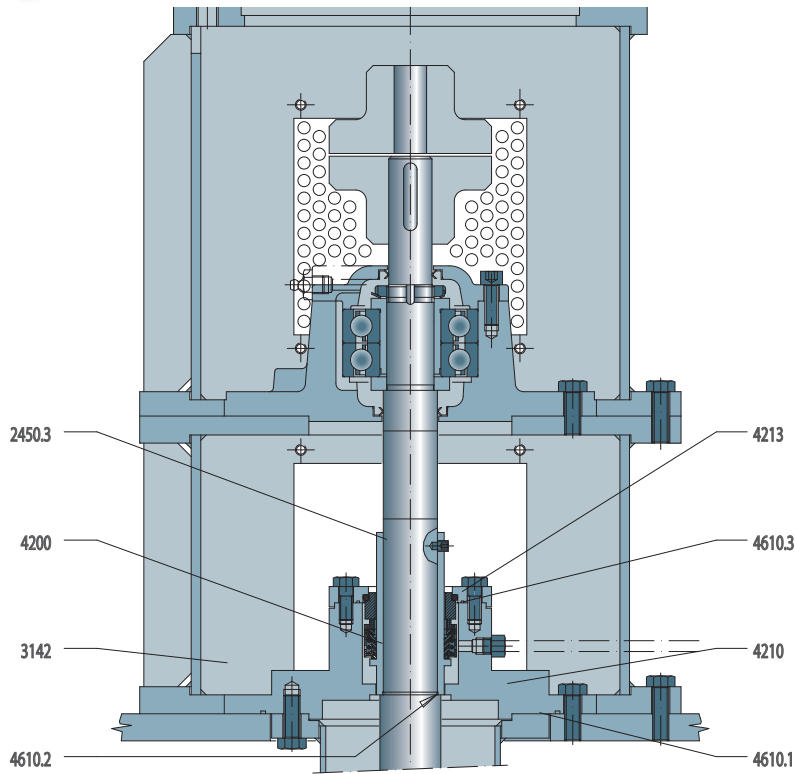

MECHANICAL SEAL VERSION
VERSIONE TENUTA MECCANICA

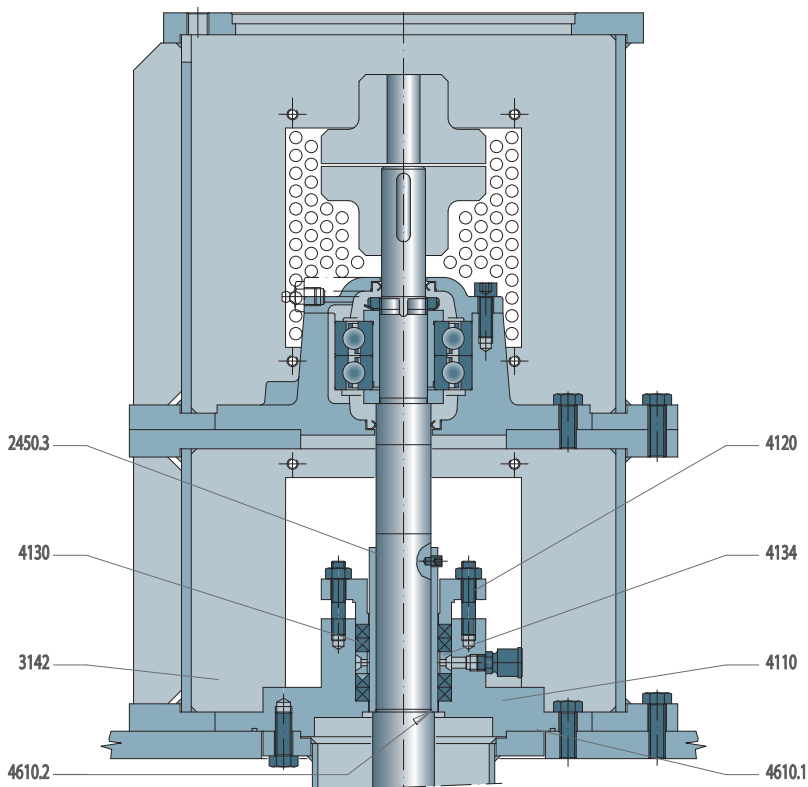

SOFT PACKING VERSION
VERSIONE TENUTA A BADERNA

Pos	Description <i>Descrizione</i>
1110	Pump casing <i>Corpo pompa</i>
1341	Support column <i>Tubo guida intermedio</i>
1343	Column pump side <i>Tubo guida lato pompa</i>
1350	Column pipe <i>Tubo premente</i>
1510	Casing wear ring <i>Anello di usura</i>
1521	Wear ring <i>Anello di usura</i>
2115	Vertical pump shaft <i>Albero della pompa</i>
2120	Intermediate shaft <i>Albero intermedio</i>
2130	Top shaft <i>Albero lato comando</i>
2200	Impeller <i>Girante</i>
2450.1	Shaft sleeve <i>Camicia d'albero</i>
2450.2	Shaft sleeve <i>Camicia d'albero</i>
2450.3	Shaft sleeve <i>Camicia d'albero</i>
2460.1	Spacer sleeve <i>Bussola distanziatrice</i>
2460.2	Spacer sleeve <i>Bussola distanziatrice</i>
2470	Centering sleeve <i>Bussola di centraggio</i>
2531	Retaining ring <i>Anello d'arresto</i>
3016	Ball bearing <i>Cuscinetto a sfere</i>
3142	Bearing lantern <i>Lanterna del cuscinetto</i>
3160	Motor stool <i>Lanterna del motore</i>
3190	Reduction ring <i>Anello di riduzione</i>
3209	Bearing housing pump side <i>Supporto lato pompa</i>
3210	Bearing housing intermediate <i>Supporto intermedio</i>
3211	Bearing housing drive side <i>Supporto lato comando</i>
3261	Bearing cover <i>Coperchio del supporto</i>
3300.1	Bearing bush <i>Cuscinetto a boccola</i>
3300.2	Bearing bush <i>Cuscinetto a boccola</i>
4110	Stuffing box housing <i>Scatola del premitreccia</i>
4120	Stuffing box gland <i>Collare del premitreccia</i>
4130	Gland packing <i>Guarnizione a treccia</i>
4134	Lantern ring <i>Anello lanterna</i>
4200	Mechanical seal <i>Tenuta meccanica</i>
4210	Mechanical seal housing <i>Scatola della tenuta</i>
4213	Mechanical seal cover <i>Coperchio della tenuta</i>
4300.1	Radial shaft seal <i>Anello di tenuta</i>
4300.2	Radial shaft seal <i>Anello di tenuta</i>
4609.1	O-Ring <i>O-ring</i>
4609.2	O-ring <i>O-ring</i>
4610.1	O-ring <i>O-ring</i>
4610.2	O-ring <i>O-ring</i>
4610.3	O-ring <i>O-ring</i>
6140	Support plate <i>Piastra di appoggio</i>
6542	Lockwasher for locknut <i>Rosetta di sicurezza</i>
6581	Impeller selflocking nut <i>Dado autobloccante</i>
6586	Locknut <i>Ghiera a tacche</i>
6700.1	Key <i>Chiavetta</i>
6700.2	Key <i>Chiavetta</i>
6700.3	Key <i>Chiavetta</i>
6700.4	Key <i>Chiavetta</i>
7021	Intermediate coupling <i>Giunto rigido</i>

MCA - VSC

INTERCHANGEABILITY <i>INTERCAMBIABILITÀ</i>	
MODELS (CANTILEVER) <i>MODELLI</i>	19
CASINGS <i>CORPI</i>	19
IMPELLERS <i>GIRANTI</i>	19
SHAFTS <i>ALBERI</i>	3
BEARING BRACKETS <i>SUPPORTI</i>	3

MATERIALS (CANTILEVER) <i>MATERIALI</i>	MAX. WORKING PRESSURE <i>PRESSIONE MAX. ESERCIZIO</i>
CAST IRON <i>GHISA</i>	10 bar
STAINLESS STEEL, BRONZE, SPECIAL ALLOY <i>ACCIAIO INOX, BRONZO, LEGHE SPECIALI</i>	16 bar

NOTE: SPECIAL EXECUTIONS EXCEEDING THE ABOVE LIMITS AVAILABLE ON REQUEST
NOTA: ESECUZIONI SPECIALI AL DI FUORI DEI LIMITI SOPRAESPOSTI REALIZZATE SU RICHIESTA

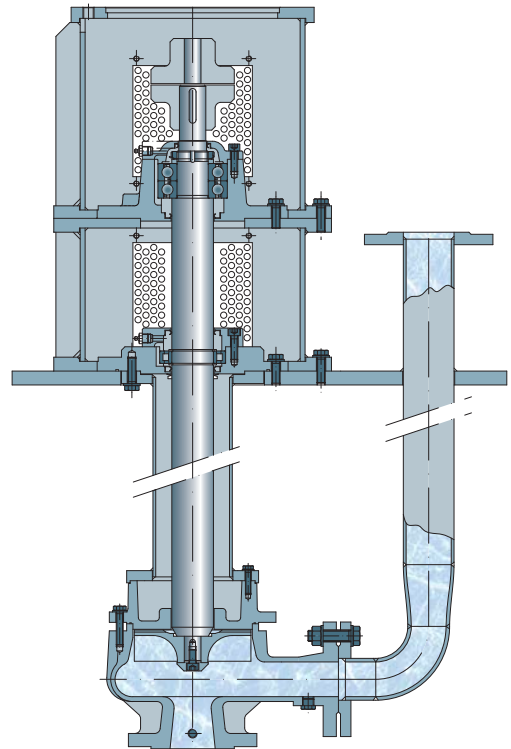

CANTILEVER LONGITUDINAL SECTION
CANTILEVER SEZIONE LONGITUDINALE

LINE-SHAFT BUSHINGS LUBRICATION OPTION

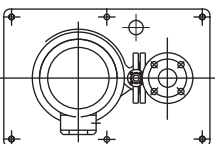
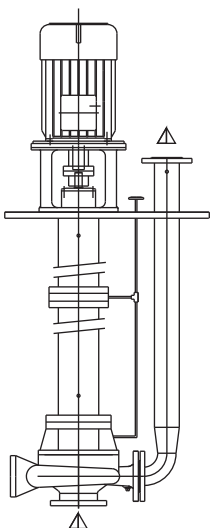

Lubrication from external source
Lubrificazione con liquido esterno

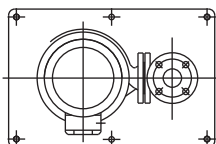
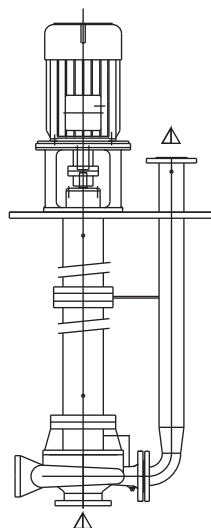

Lubrication with pumped liquid
Lubrificazione con liquido pompato

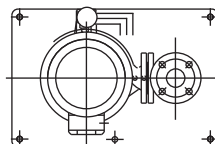
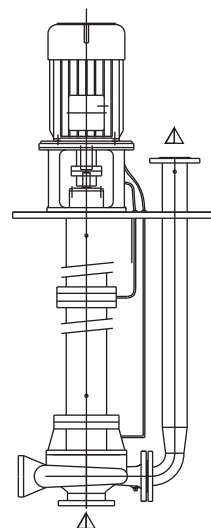

Grease lubrication by automatic greaser pump
Lubrificazione a grasso con pompa automatica

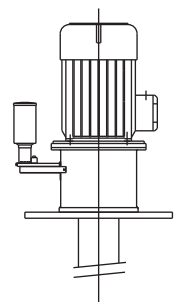



POMPE GARBARINO S.p.A.

Headquarters:

Via Marengo, 44 - 15011 Acqui Terme (AL) - Italy - Tel. +39 0144.388671 - Fax +39 0144.55260

E-mail: info@pompegarbarino.it

Milan Branch:

Viale Andrea Doria, 31 - 20124 Milano - Italy - Tel. +39 02.67070037 - Fax +39 02.67070097

www.pompegarbarino.com