

**Side channel pump PN 40**  
self-priming with special NPSH stage

**SRZS**

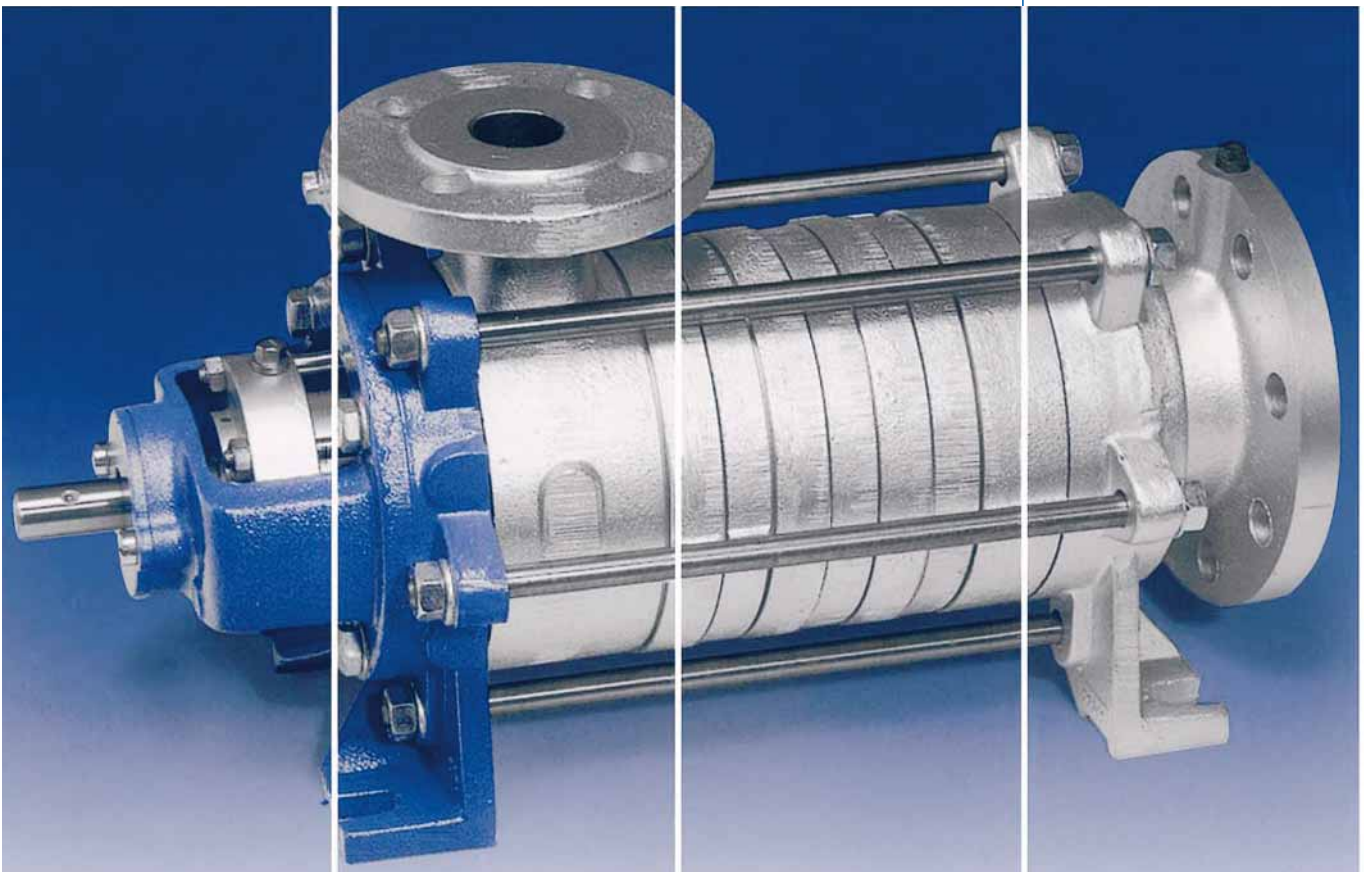

**Technical description**

SRZS pumps are self-priming side channel pumps in multistage construction capable of handling aerated liquids and having a special suction impeller with an axial suction branch. This pump is a combination of centrifugal pump and side channel pump and its special characteristics are:

- extremely low NPSH-value
- capable of handling aerated liquids
- self-priming
- low noise level
- positive suction head below 0.5 m

Taking into account their various material designs, these pumps have been especially conceived for the following situations:

- difficult suction conditions
- pumping liquids approaching the boiling point
- low positive suction heads
- liquids with low steam pressures

#### Important:

Pump types of this series consist of components of hydraulic II. They show a uniform performance level and they are - also referring to their dimensions - identical to pump types of other German producers.

## Application:

SRZS pumps are suitable for:

- all clean and slightly contaminated liquids
- aerated or fast steaming liquids
- boiler feed water up to 220°C

These pump types are specially applied in the areas: chemical and petrochemical industry, installation engineering and process engineering as well as installations of distillate tanks and beverage industry.

For condensates resp. boiler water up to 120°C pumps in standard design are suitable; pumps in cooling-design (K) are applicable for handling liquids up to 220°C.

Using only one shaft seal on the discharge side permits pumping liquids in a high vacuum range, because there is no penetration of air on the suction side.

**For handling liquefied gas a special design of this pump is available.**

#### Important application fields

- chemical and petrochemical industry
- boiler feed installations
- refrigerating installations
- process engineering
- tank installations
- booster installations

Please note that SRZS pumps are also available with magnetic drive.

## Technical data:

Capacity: 0,3 - 35 m<sup>3</sup>/h  
 Head: 5 - 350 m  
 Speed: 1450 (1750) 1/min.  
 Temperature: -40° C to +220° C  
 (660 series up to + 180° C)  
 Working pressure: 40 bar  
 Viscosity: max. 230 cst  
 Suction head: max. 7.0 m  
 NPSH required: 0,4 - 1,7 m  
 Proportion of gas: max. 50 %  
 Drive: three-phase motor 0,55 - 55 kW



## Characteristics of construction

- side channel pump with special NPSH stage
- modular construction
- carbon sleeve bearing
- pressure relieved impellers
- vane impellers 2. to 9. stage (ill. 1)
- centrifugal pump impeller, 1. stage (ill. 2)
- flange according to DIN 2501, PN 40
- suction side: NW 40 - 100
- discharge side: NW 20 - 65
- one ball bearing
- direction of rotation: left side
- shaft sealing resp. gland or mechanical seal



ill. 1

ill. 2

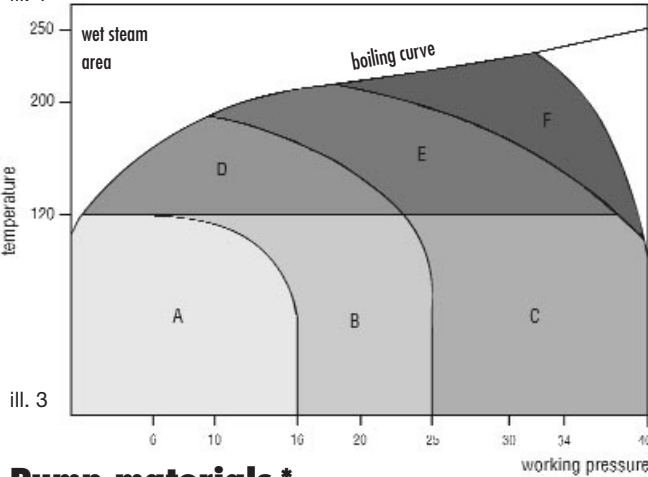

ill. 3

## Pump materials \*

part no.	item	material code				
		10	12	32	60	62
106	suction casing	GG 25	GG 25	1.4408	GGG 40.3	GGG 40.3
107	discharge casing	GG 25	GG 25	1.4408	GGG 40.3	GGG 40.3
108	stage casing	GG 25	GG 25	1.4581	GGG 40	GGG 40
109	stage casing	GG 25	GG 25	1.4470	GGG 40	GGG 40
114	side channel casing	GG 25	GG 25	1.4470	GGG 40	GGG 40
182	foot	GGG 40	GGG 40	GGG 40	GGG 40	GGG 40
210	shaft	1.4021	1.4021	1.4571	1.4021	1.4021
230	impeller	brass	1.4059	1.4581	brass	1.4059
231	suction impeller	GBz 10	1.4059	1.4581	GBz 10	1.4581
330	bearing support	GG 20	GG 20	GG 20	GG 20	GG 20
411	gasket	Teflon	Teflon	Teflon	Teflon	Teflon
545	bearing bush	bronze	carbon	carbon	bronze	carbon

Technical changes reserved.

## Pumps for temperatures higher than 120° C up to 220° C (K-design):

For the selection of pumps resp. of their design you can proceed according to illustration no.3.

On illustration no. 4 the minimum requirements for materials and shaft seals are represented in the different sections.

On principle pumps in K-design have the following constructive modifications:

- increased clearance between impeller and stage
- high temperature bearing
- heat-resistant paint
- cooling connections at the foot (1-2 l/min, max. 10 bar)
- compensation of thermal expansion

The K-execution requires a cooling of the shaft sealing.

zone	material 2*	shaft seal 1*	cooling
A	10	G11	-
B	10	G12	-
C	60	G12	-
D	10	G12	K
E	62	G12	K
F	32	G12/Q32	K

1\*) Standard

2\*) minimum requirements

ill. 4

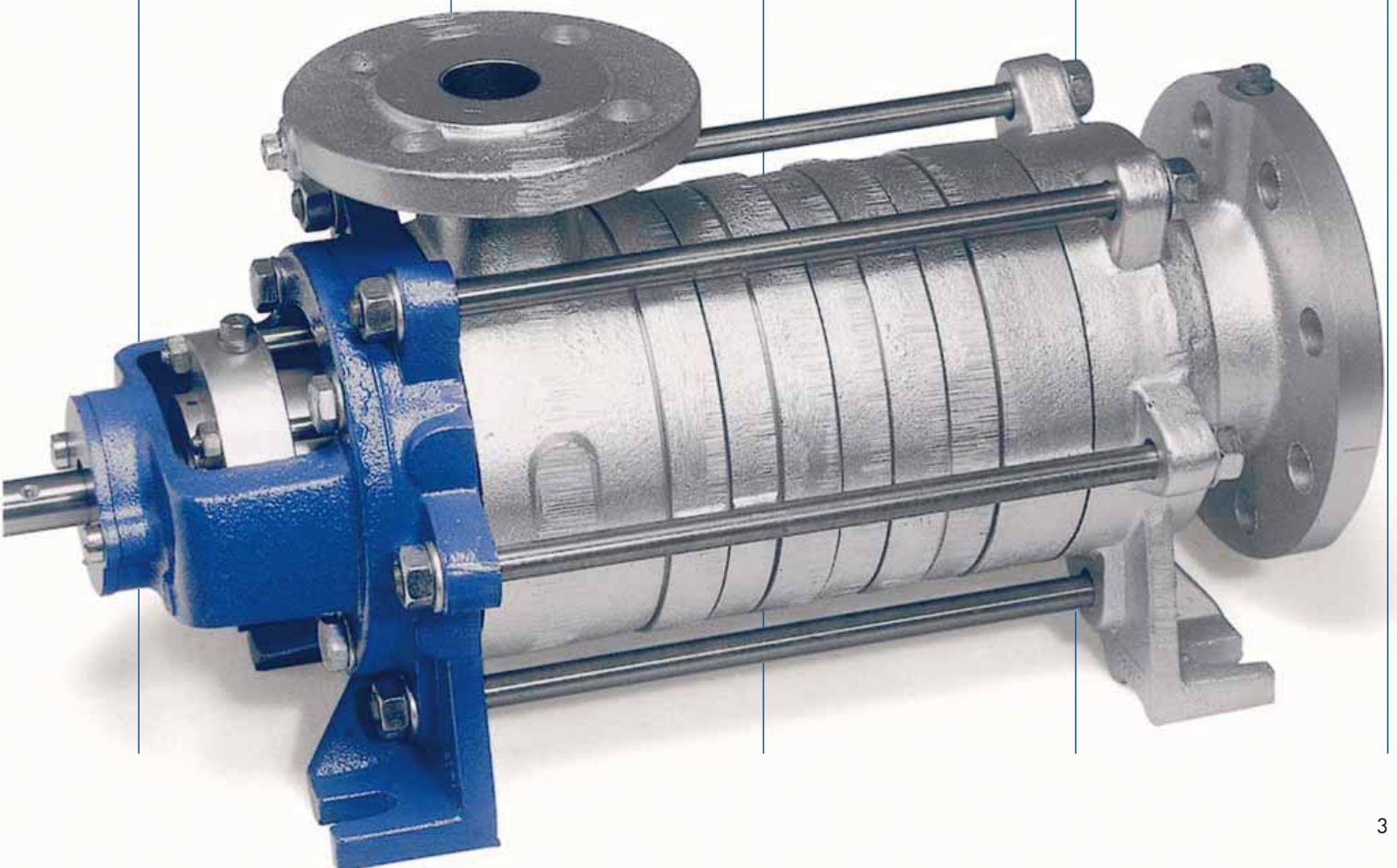
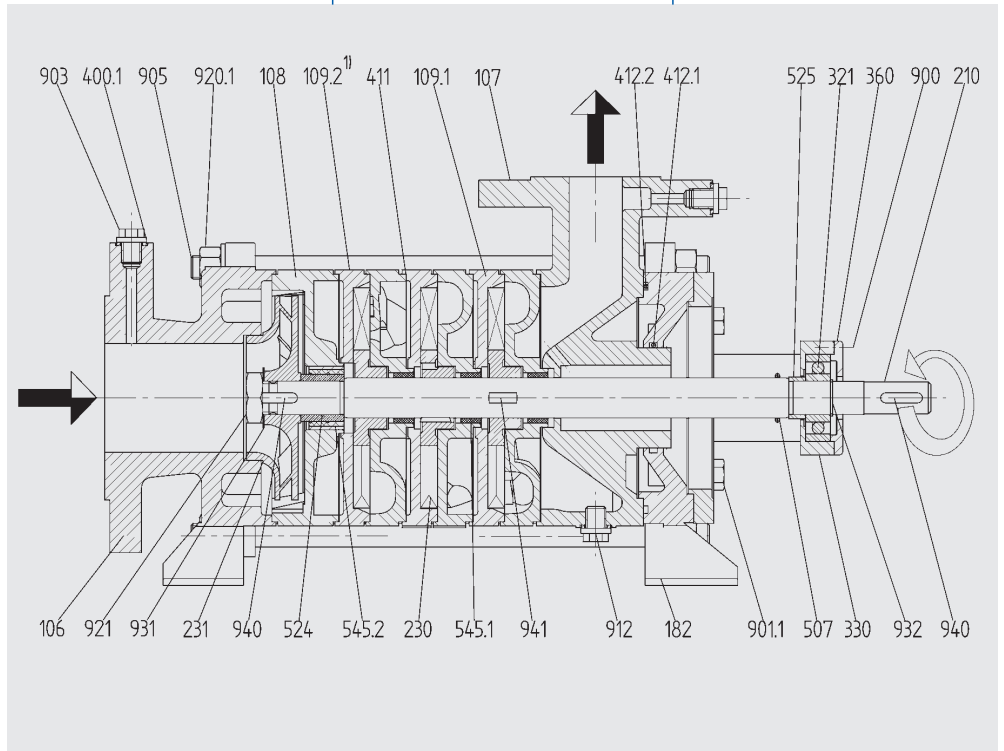

## Dimensions

- $A_E$  = connection for drain
- $A_M$  = connection for manometer
- $A_{k1}$  = connection for cooling liquid (outlet)
- $A_{k2}$  = connection for cooling liquid (inlet)
- U = by-pass pipe

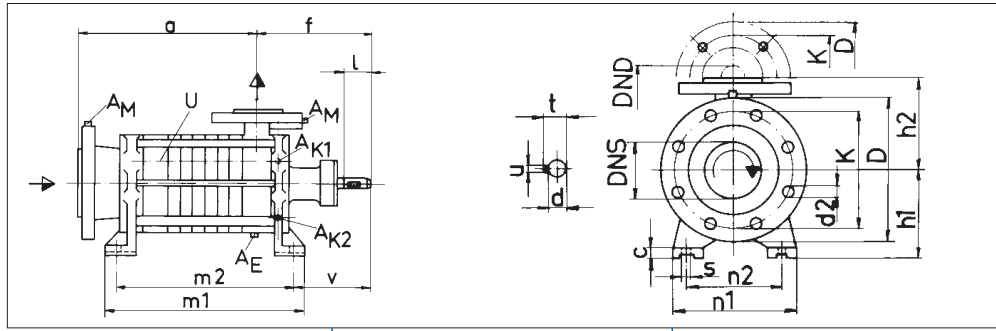

serie	DN <sub>S</sub>	DN <sub>D</sub>	c	f	h <sub>1</sub>	h <sub>2</sub>	n <sub>1</sub>	n <sub>2</sub>	v	d	l	t	u
110	40	20	10	171	100	100	140	105	113	14	25	16,1	5
220 / 330	65	32	13	201	112	132	170	135	134	19	40	21,4	6
440	80	40	15	195	132	140	195	155	142	24	45	26,9	8
550	100	50	18	237	160	165	215	170	159	28	50	30,9	10
660	100	65	20	262	180	180	245	195	172	32	65	35,3	10

serie	1			2			3			4			5			6			7			8		
	a	m <sub>1</sub>	m <sub>2</sub>	a	m <sub>1</sub>	m <sub>2</sub>	a	m <sub>1</sub>	m <sub>2</sub>	a	m <sub>1</sub>	m <sub>2</sub>	a	m <sub>1</sub>	m <sub>2</sub>	a	m <sub>1</sub>	m <sub>2</sub>	a	m <sub>1</sub>	m <sub>2</sub>	a	m <sub>1</sub>	m <sub>2</sub>
110	195	238	204	229	272	238	263	306	272	297	340	306	331	374	340	365	408	374	399	442	408	433	476	442
220 / 330	213	263	227	253	303	267	293	343	307	333	383	347	373	423	387	413	463	427	453	503	467	493	543	507
440	268	290	259	323	345	314	378	400	369	433	455	424	488	510	479	543	565	534	598	620	589	653	675	644
550	305	350	313	380	425	388	455	500	463	530	575	538	605	650	613	680	725	688	755	800	763	830	875	838
660	338	391	353	428	481	443	518	571	533	608	661	623	698	751	713	788	841	803	878	931	893	968	1021	983

Possibility of flange execution according to DIN 2512 with slot and drilled according to ANSI against surplus price.

flange connection dimensions according to DIN 2501 PN 40							
DN <sub>S,D</sub>	20	32	40	50	65	80	100
K	75	100	110	125	145	160	190
D	105	140	150	165	185	200	235
d2 x number of holes	14 x 4	18 x 4	18 x 4	18 x 4	18 x 8	18 x 8	22 x 8

## Installation plan

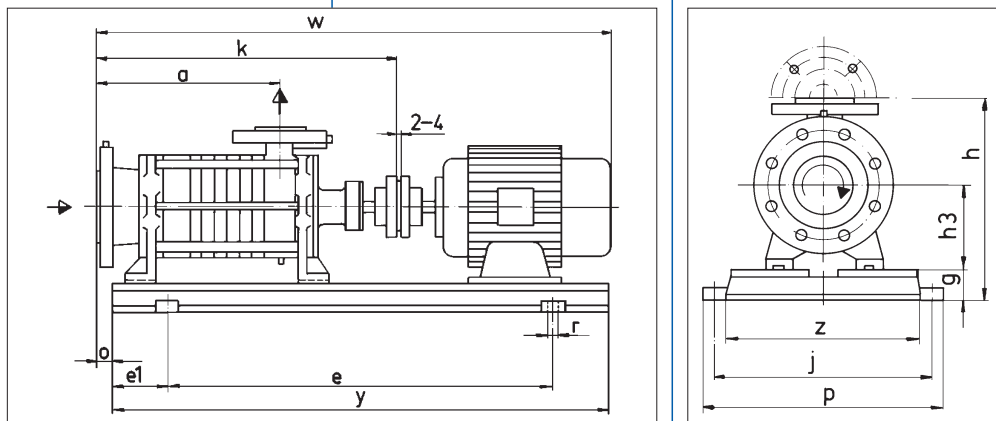

series	motor		coup-ling	base plate	weight (kg)		a	k	o	h	h3	w	e	e1	g	i	p	r	y	z
	size	kW			pump	aggreg.														
111	71	0,37	58	180	16	35	195	367	25	240	100	599	445	77,5	40	255	290	15	600	235
	80	0,55			37	635														
112	80	0,55	58	181	18	45	229	401	25	245	100	669	550	90	45	305	340	15	730	270
	80	0,75			46	703														
	90 S	1,1			48	695														
113	80	0,75	58	181	20	48	263	435	25	245	100	763	550	90	45	305	340	15	730	270
	90 S	1,1			50	730														
	90 L	1,5			53	755														
114	90 S	1,1	68	181	22	52	297	469	25	245	100	763	550	90	45	305	340	15	730	270
	90 L	1,5			55	789														
	100 L	2,2			61	833														
115	90 S	1,1	68	181	24	54	331	503	25	245	100	797	550	90	45	305	340	15	730	270
	90 L	1,5			57	823														
	100 L	2,2			67	872														
116	90 L	1,5	68	182	26	63	365	537	25	245	100	857	650	100	45	308	340	15	850	280
	100 L	2,2			69	542														
	100 L	3			73	906														
117	90 L	1,5	68	182	26	65	399	576	25	245	100	891	650	100	45	308	340	15	850	280
	100 L	2,2			71	940														
	100 L	3			75	957														
118	100 L	2,2	80	183	30	78	433	610	25	250	100	974	730	150	50	385	420	18	1030	320
	100 L	3			82	262														
	112 M	4			96	112														



## Performance curve

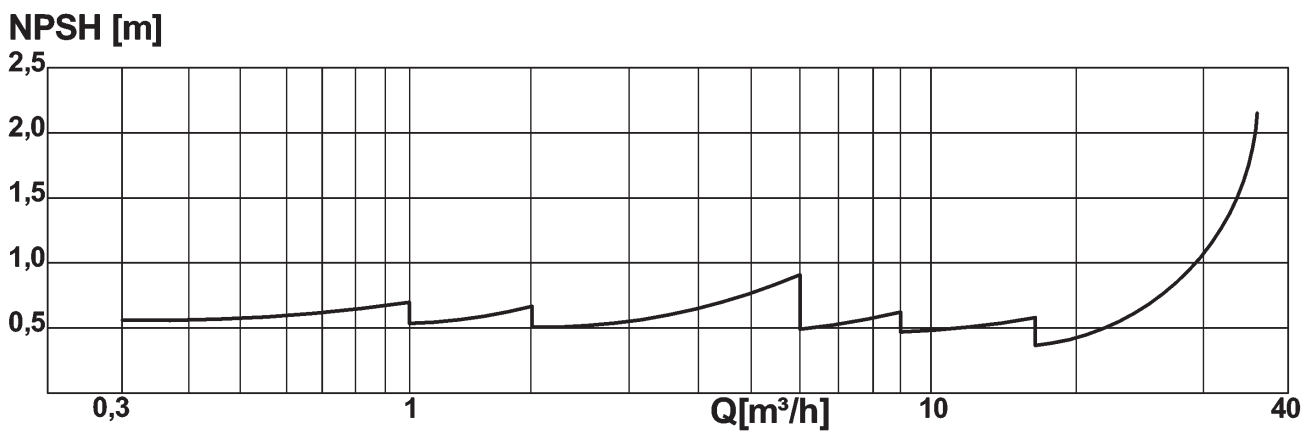
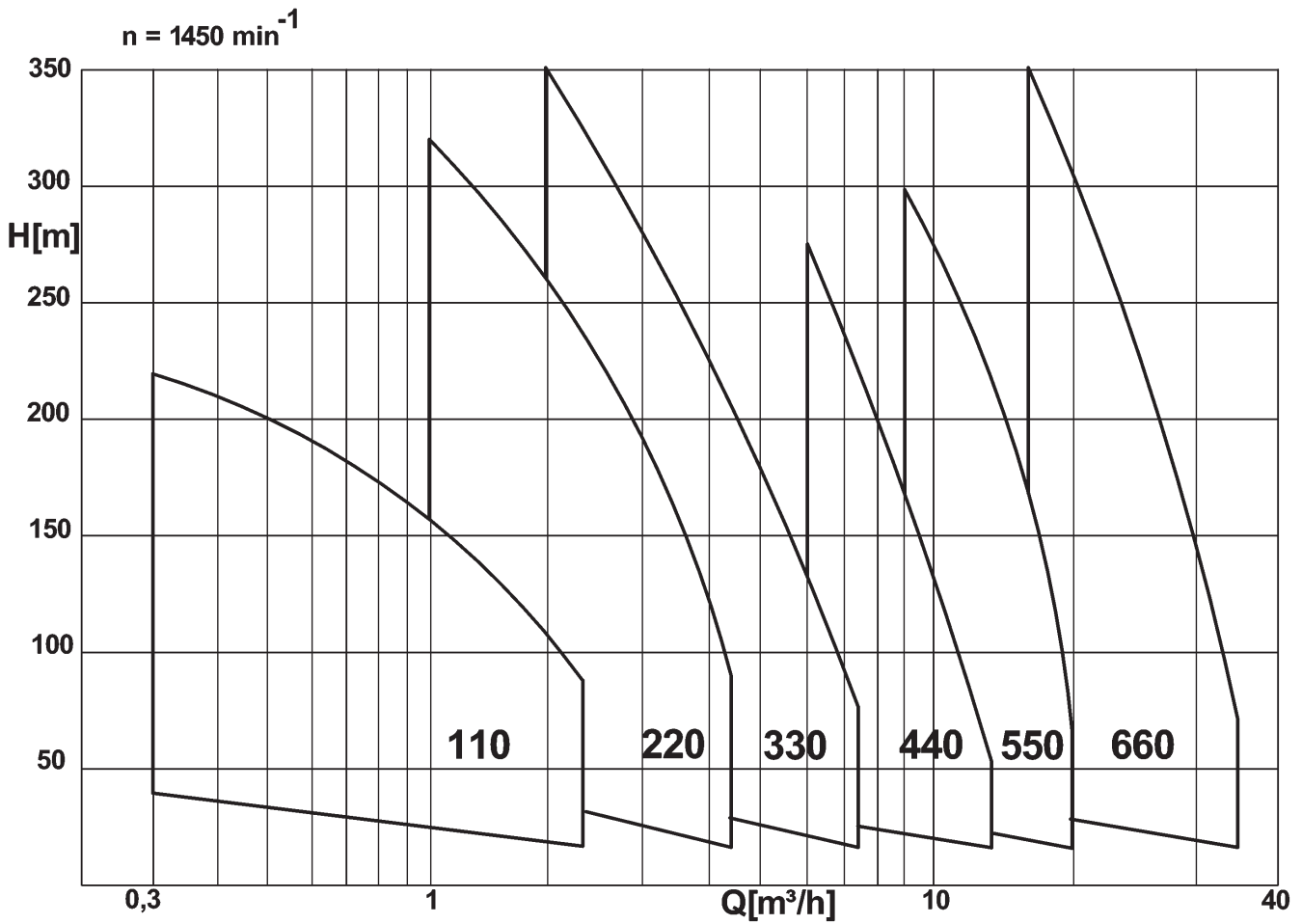

The technical documentation includes detailed curves.

Attention: The limit on the left side of the curve represents  $Q_{\min}$ . The capacity has not to be continually inferior to this value. Otherwise pump could be damaged. For start-up and during the operation the suction and the discharge valve must always be open. In case of capacity fluctuations we advise to use a by-pass.

## Shaft seal (standard):

### Single mechanical seal:

G 11: unbalanced single mechanical seal (up to 16 bar)

G 12: balanced single mechanical seal (up to 40 bar)

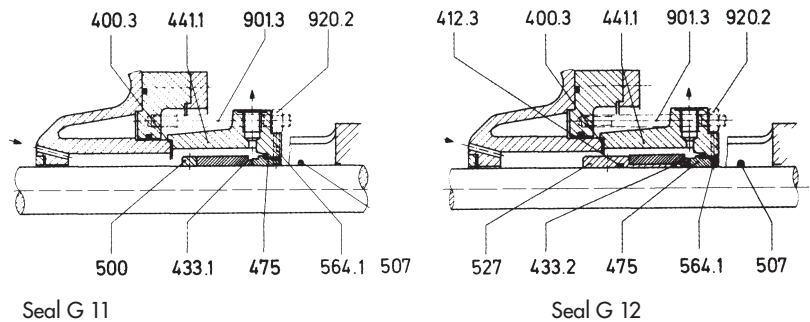

### Double mechanical seal: (Option)

G 15: unbalanced double mechanical seal (back to back) (up to 16 bar)

G 16: balanced double mechanical seal (back to back) (up to 40 bar)

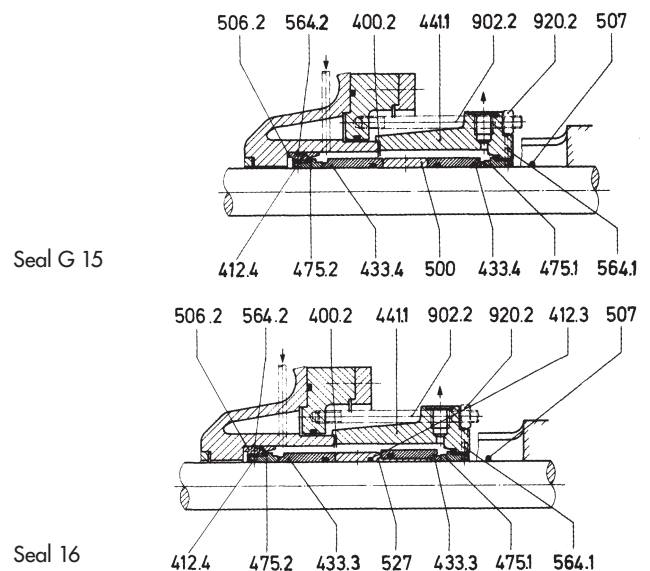

### Quench:

Q 31: unbalanced single mechanical seal with quench connection up to 16 bar (without ill.)

Q 32: balanced single mechanical seal with quench connection up to 40 bar.

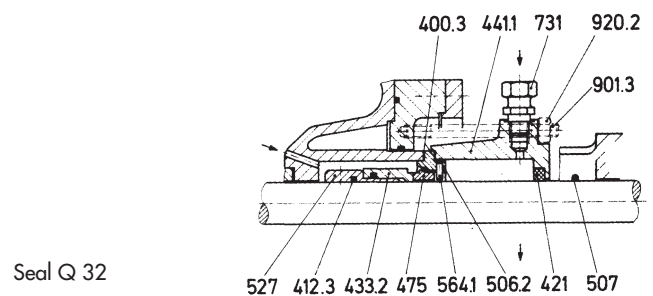

**For all variants there is the possibility of cooling or heating of the seal chamber.**

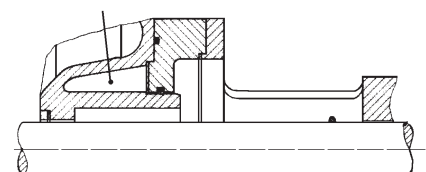

**The SRZS is also available with magnetic drive and canned motor.**



**address:**  
**SERO PumpSystems GmbH**  
Industriestraße 31  
D-74909 Meckesheim near Heidelberg  
Germany

**contact:**  
Phone + 49 (62 26) 92 01-0  
Fax + 49 (62 26) 92 01-40  
info@seroweb.de  
sales@seroweb.de  
service@seroweb.de

**information:**  
[www.seroweb.de](http://www.seroweb.de)