

SafeGuard™
Predictive Maintenance
Solution





Introducing Griswold's SafeGuard™ Predictive Maintenance Solution

With pumps being the heart of the process, an unexpected failure is devastating. Knowing this, over the years the pump industry has improved pump reliability as well as developed tools to monitor pump performance, but these tools have resulted in nothing more than a “check engine light.” You know there is a problem, now what? Griswold is pleased to introduce a new solution for the centrifugal pump industry, SafeGuard, a predictive maintenance solution. SafeGuard is a system that not only alerts the plant of a pump issue, but provides actionable guidance to resolve it.



Common Industry Challenges with Pump Failure

Lost Revenue

- Production is disrupted
- Batch failures
- Recalls
- Lost revenue (\$/hr)

SAFEGUARD SOLUTION

SafeGuard provides proactive alerts when the health of the pump changes. This allows a plant to be more strategic about its downtime.



Unexpected Downtime

- Costly repairs
- Expedited parts/freight
- Overtime
- Lost revenue (\$/hr)

SAFEGUARD SOLUTION

SafeGuard continuously monitors the pump 24/7 and will alert the operator prior to pump failure, giving the plant enough time to prepare and fix the problem.



Limited Pump Health Visibility

- Expertise required
- On-site 24/7
- Unable to determine health of pumps in remote locations

SAFEGUARD SOLUTION

SafeGuard monitors the pump's health via wireless access and status can be easily accessed from any computer. Notifications are sent via email if the pump's health changes.



Costly Diagnostics

- Hard-to-find root cause
- Time consuming
- Repairs chase symptoms
- Expertise required

SAFEGUARD SOLUTION

If an alert occurs, SafeGuard algorithms are detailed enough to not only determine the problem, but also provide clear guidance on how to resolve the issue. If more detail is required, engineers are standing by to provide personal support.



Current Industry Solutions are Lacking...

Current diagnostic technologies fail to meet the expectations of what a plant really needs. Many of these technologies only provide a warning signal, lacking details about the root cause or the ability to offer guidance on a resolution. While some provide data, it's only useful to diagnostic experts and does little to support the local maintenance team on a day-to-day basis. Lastly, most solutions are only designed to monitor the health of the pump and ignore the health issues associated with the motor.

Compare and Contrast	SafeGuard	Predict-Plus®	iALERT® 2	IPS Beacon™ 2
24/7 Proactive alerts	Yes	Yes	No	No
Identifies failure mode*	Yes	No	No	No
Clear actionable repair guidance	Yes	No	No	No
Monitoring of pump and motor (std.)	Yes	No	No	No
Continuous cloud connectivity	Yes	Yes	No	No
Includes web application access	Yes	Yes	No	No
Battery life	Free Replacement	External Power	3 Years Max	4 Years Max
All-inclusive service	Yes	No	No	No

Predict-Plus is a registered trademark of PumpWorks™
 iAlert®2 is a registered trademark of ITT Goulds Pumps
 IPS Beacon™ 2 is a registered trademark of Flowserve®

*Extended list of failure modes available on page 7

SafeGuard takes Smart Pump Technology to the Next Level...

The SafeGuard Smart Pump System allows both the pump and the motor to be remotely monitored 24/7 with continuous Cloud connectivity. If an issue occurs, a proactive alert is automatically generated that includes clear actionable guidance that can be easily followed by maintenance personnel to resolve the root cause of the issue - the first time.

Choosing SafeGuard is Simple. Affordable, All-Inclusive, Annual Subscription Fee

- No upfront hardware cost
- Free battery replacements
- Free hardware replacements*
- Free access to web application to manage all equipment
- Cellular router with data service included

*per warranty policy

Certifications



- IP66 - Node (generally equivalent to NEMA 4X)
- IP68 - Sensors/End Points (generally equivalent to NEMA 6P)
- UL 94-V0, RoHs compliant



30%
Lower
Maintenance
Costs



75%
Fewer
Breakdowns



20%
Less
Energy



45%
More
Uptime

Potential Cost Savings

Rotating Shaft Replacement:	\$700 - \$5,000
Seal Failure:	+\$700 - \$10,000
Pump Replacement:	+\$2,500 - \$30,000
Motor Replacement:	+\$500 - \$30,000
Coupling Replacement:	+\$150 - \$1,500
Manual Vibration Analysis:	+\$1,000+ per unit
Onsite Maintenance Resource:	\$50+/hr
Process Disruption:	\$\$\$\$\$



How It Works

SafeGuard is designed to monitor all types of centrifugal pumps. Four battery-powered sensors (end points) are included in the SafeGuard system as well as a node/sensor reader. Two of the end points are installed on the pump and two are installed on the motor. All four sensors work in unison to predict the full health of the pump and motor. This allows for a complete diagnostic analysis that reads the system's tri-axial vibration, temperature and electromagnetic values for the pump as well as the motor, coupling and foundation.



Tri-Axial Vibration

Tri-Axial Vibration Reading:

The equipment's vibration signature provides extensive details about its health and is used to identify bearing failure, misalignment, cavitation, pipe strain and much more.



Temperature

Temperature Reading:

Elevated temperature is an indication of bearing failure, inadequate bearing lubrication and other problems. Studying the temperature trend can detect thermal fault signatures and provide additional insight.



Electromagnetic

Electromagnetic Reading:

Allows the sensors to monitor the true RPM and diagnose electrical faults to not only monitor the health of the motor, but also enhance the vibration analysis accuracy.

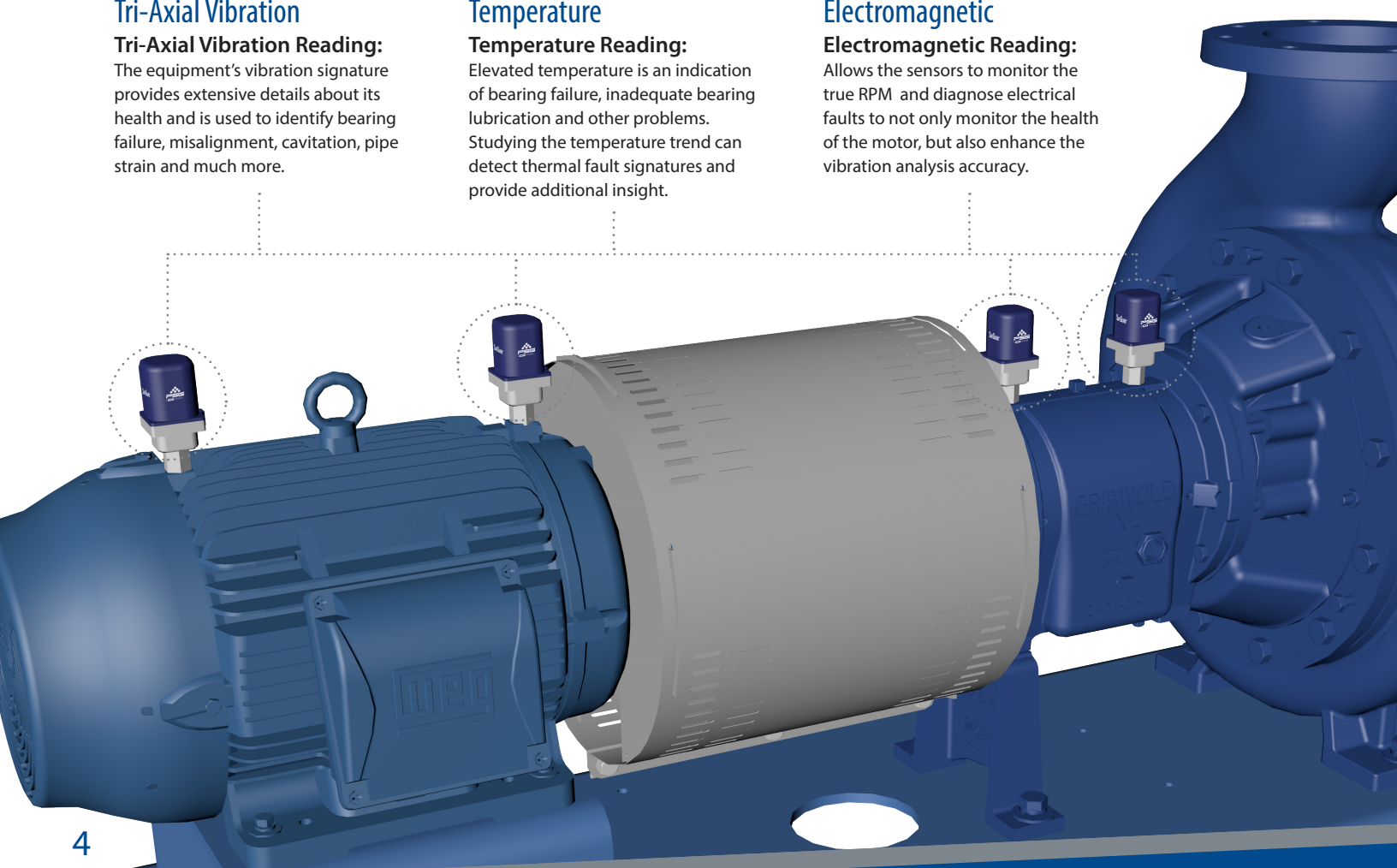

The data (vibration, temperature and electromagnetic readings) are collected into the node and transferred to the Cloud (via WiFi or included cellular data service) to be analyzed. The Cloud uses a set of machine-learning algorithms to determine the overall health of the equipment.

When a potential issue is identified, the algorithms analyze the data to determine its root cause: bearing failure, coupling mis-alignment, or others. An extended list of actionable alerts can be found on page 7. All findings can be found by logging into the SafeGuard system online or received via an automated email report.

Facility Dashboard

Once online, the SafeGuard website will provide a high-level overview of the pump's health. If multiple SafeGuard systems are installed within the plant, the SafeGuard website will provide a summary of all the pumps installed.

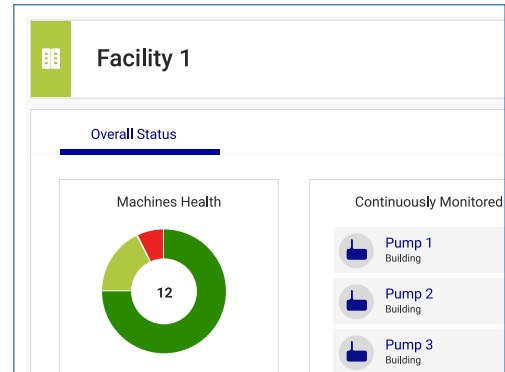

Pump Details

If a health issue arises on one of the pumps, the SafeGuard system will immediately provide an alert as well as provide detailed actionable repair guidance backed by summarized data.

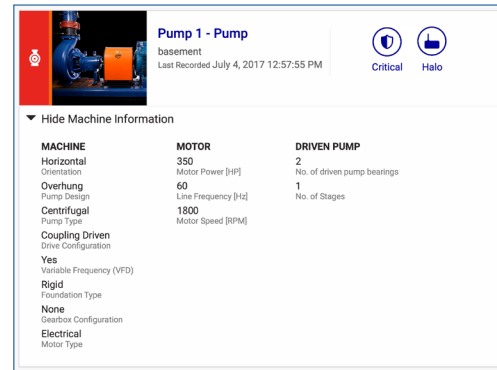

Automated Reports

Reports are automatically emailed when the status of the equipment changes (i.e. health transitions from *acceptable to monitor*).

The report content can be customized to contain desired information.

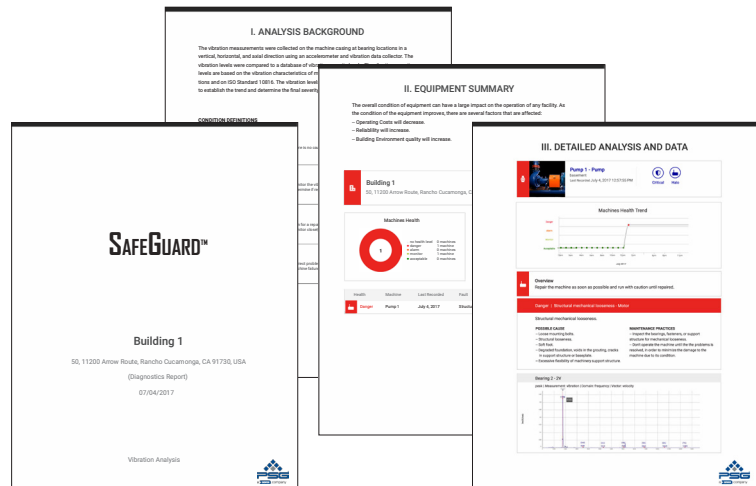

Software Capabilities

Overall Pump Health



Quickly identify the health of all pumps through a color coded dashboard.

Pump Details

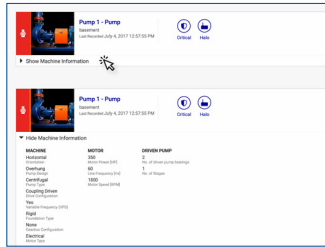

Easily document and access pump details: installation photo, asset numbers, serial numbers, installation details, operation details.

Machine Health Trend

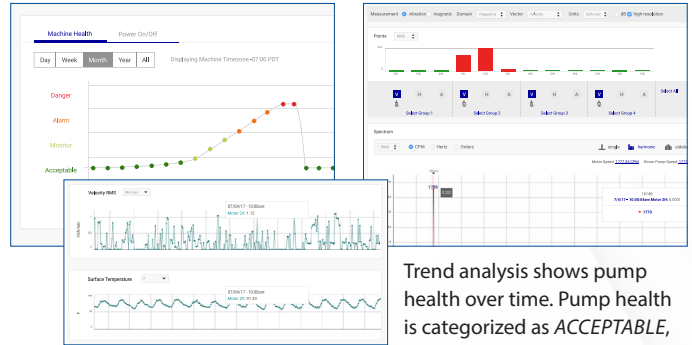

Trend analysis shows pump health over time. Pump health is categorized as *ACCEPTABLE*, *MONITOR*, *ALARM* or *DANGER*.

Failure Identification and Actionable Repair Instructions

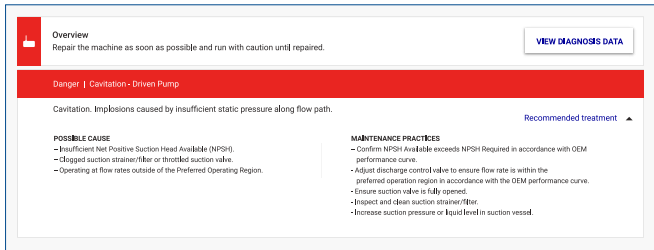

When a possible failure is detected, the failure mode, along with clear actionable guidance is shown on the pump dashboard

Report

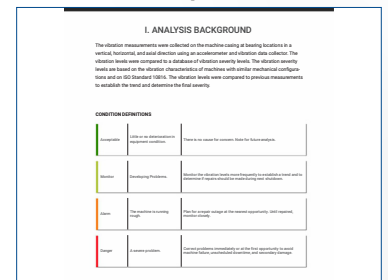

Automatically or manually generated when equipment health changes. Reports are fully customizable to include basic to complete data. Reports are distributed via email and created in .pdf format.

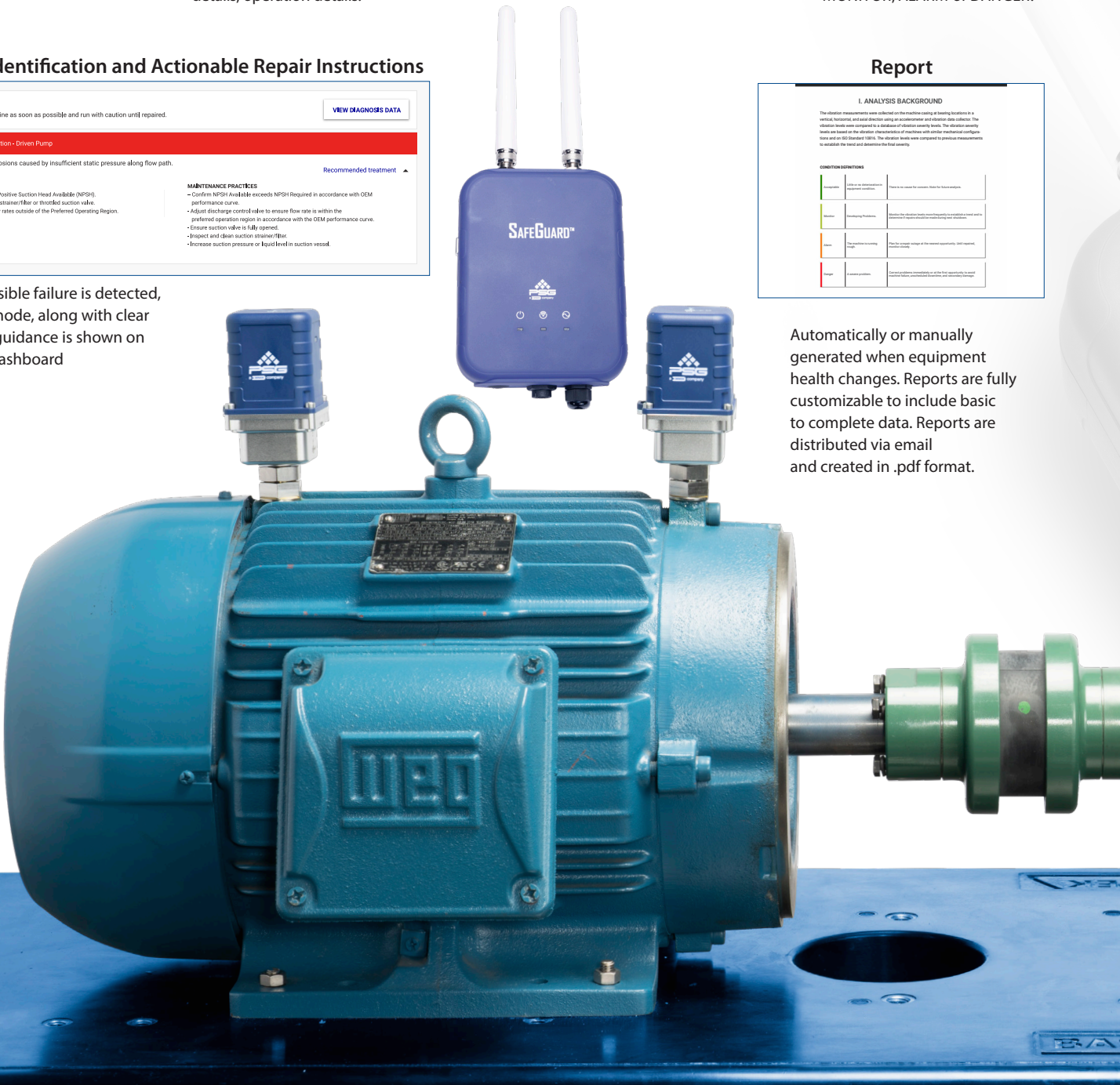

More than 20 Failure Modes and Counting...

Pump

- Impeller imbalance
- Pump soft foot
- Shaft eccentricity
- Vane pass frequency
- Bearing lubrication issues
- Bearing wear
- Cavitation
- Pipe strain

Motor

- Motor soft foot
- Stator eccentricity
- Rotor eccentricity
- Loose stator windings
- Loose rotor bars
- Cracked rotor bars
- Loose connections
- Worn/eccentric fan sheave
- Worn/eccentric motor sheave

Unit

- Coupling misalignment
- Baseplate (foundation) looseness
- Electrical faults
- Electricity discharge through bearing

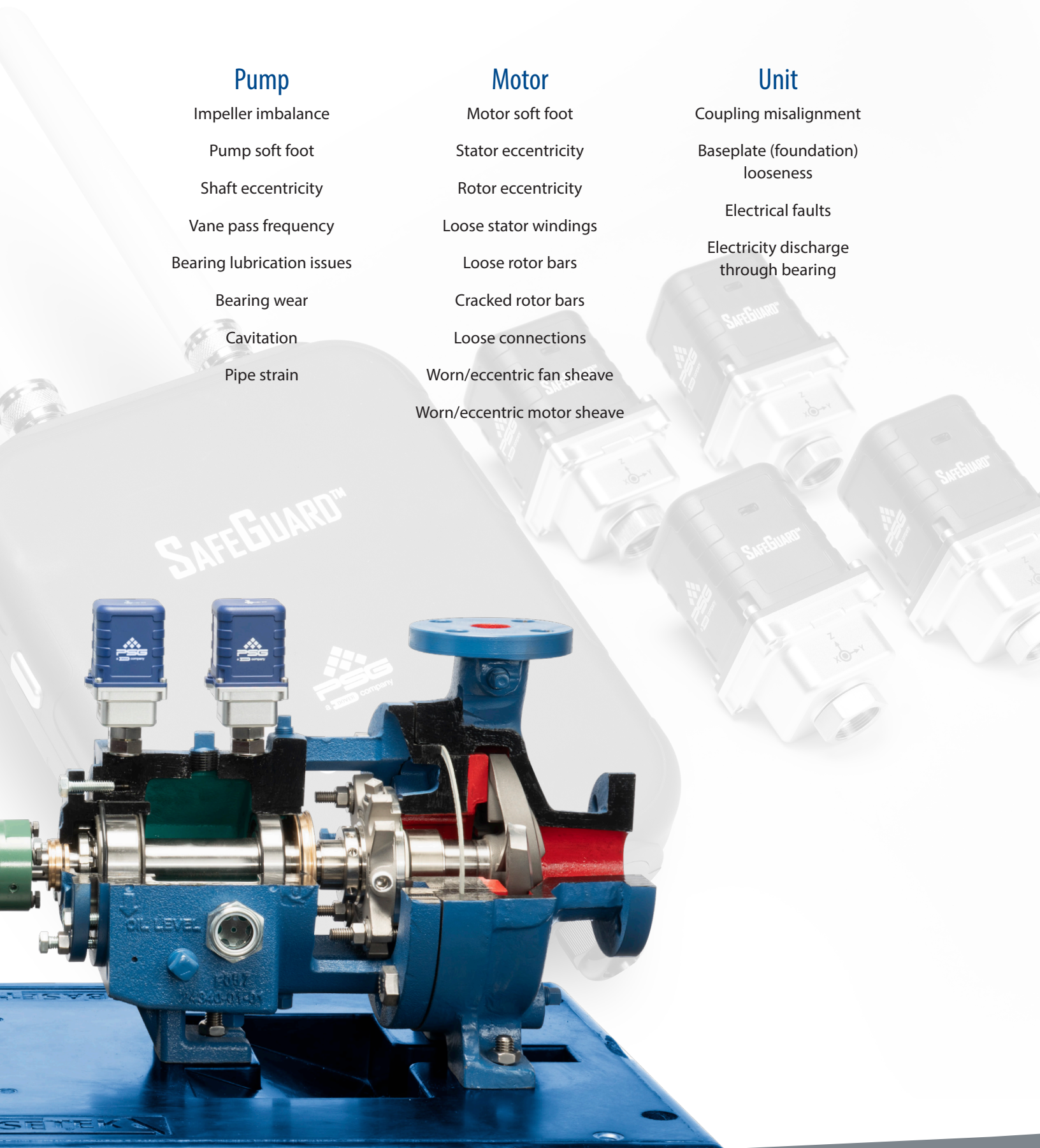

Where Innovation Flows

Griswold™ is a premier manufacturer of centrifugal pumps and baseplate systems. With engineering expertise, lean manufacturing, testing capabilities, and exceptional customer support, Griswold meets its customers' most demanding application requirements, all while minimizing project costs. Griswold—headquartered in Grand Terrace, California, USA—is part of PSG®, a Dover Company.

SafeGuard™ is a registered trademark of PSG, a Dover Company. SafeGuard is powered by Augury, Inc.

For more information on Griswold and SafeGuard, please contact your local distributor today at:

griswoldpump.com



PSG
22069 Van Buren Street
Grand Terrace, CA 92313-5607 USA
P: +1 (909) 512-1262 • F: +1 (909) 783-3440
griswoldpump.com

PSG® reserves the right to modify the information and illustrations contained in this document without prior notice. This is a non-contractual document. 11-2018

Authorized PSG® Partner: